

BEGV606M

μP Display Embedded System

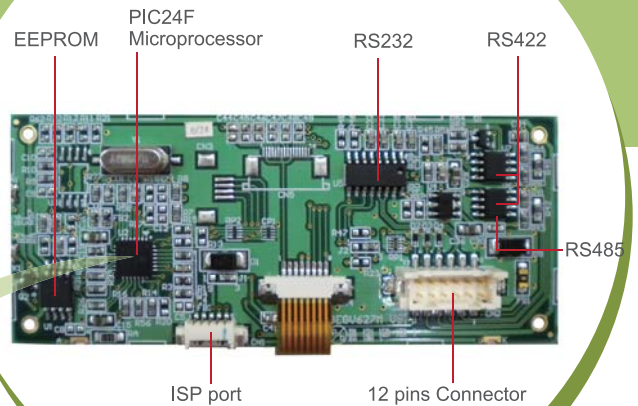
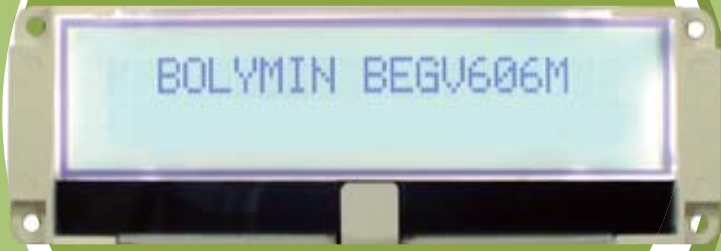

Your 64KB
application program
here!

Features

- High performance, Low power PIC 16-bit microprocessor
- Built-in 64KB ISP Flash memory / 8KB SRAM
- On board updateable 64KB EEPROM (128KB option)
- 1 x RS485 / 422 / 232, 1 x RS232
- Current consumption 35mA
- 20 x 2 character monochrome STN LCD, with font bank
- On-chip power-on reset (POR) and programmable watchdog reset
- Comprehensive set of development tools and application notes for self programming
- RS485 / 422 / 232 driver, I²C EEPROM driver, LCM driver and utility are supported
- Dimension (W x H x D): 116 x 37 x 15mm

Hardware Specifications

Processor

- Microchip PIC24FJ64GA002 16-bit microprocessor

Memory

- 64KB in-system programmable flash
- 8KB internal SRAM
- 64KB x 1 external I²C CMOS EEPROM (option: 64KBx2)

Display Interface

- Support I²C 20 x 2 character monochrome STN LCD (edge LED white backlight)

RS232 / 422 / 485 Port

- Support dual serial port, one is three-wired RS232, another is shared in among RS232/422/485 port by option

Software Utilities

- Support RS232 / 422 / 485 driver, I²C EEPROM driver, and LCM driver for free

DC Requirement

- DC4.5V~5.5V

Certifications

- CE Class B (NO.CB10101101)



BOLYMIN, INC.

Packing List

- BEGV606M Embedded System
- User Manual
- Software Utility Disc
- ICD 3 and ISP Cable (option)

BEGV606M BLOCK DIAGRAM

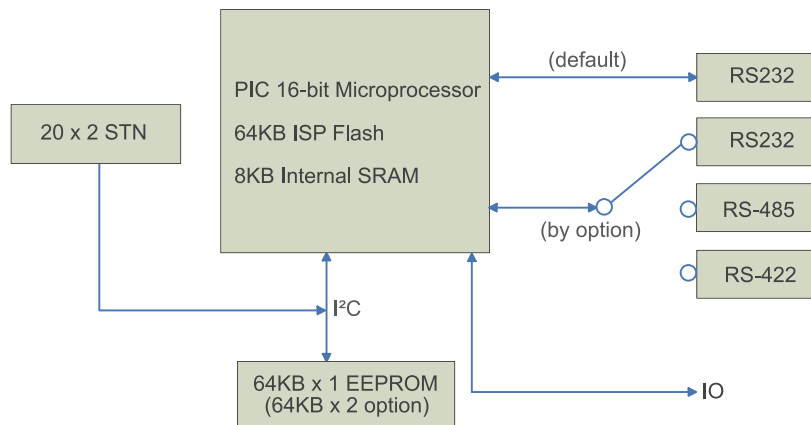

Pin Mapping Table

PIN NO.	Signal	PIN NO.	Signal
1	VDD	7	422TP/485P/TX1
2	GND	8	IOA
3	422RP	9	422TN/485N/RX1
4	TX0	10	IOB
5	422RN	11	/RST
6	RX0	12	IOC

Order Information

Parts NO.	Description	RS232-A	RS232-B	RS422	RS485
BEGV606M	Dual RS232	☆	☆		
BEGV606M1	One RS232	☆			
BEGV606M2	One RS232/One RS422	☆		☆	
BEGV606M3	One RS232/One RS485	☆			☆

Display: FSTN/Gray LCD,LED/White Backlight(Default)

