

VHF-Transceiver Family

AR620X-(X1X)

AR620X-(X2X)

RT6201-(X10)

RT6201-(X20)

RCU6201-(X12)

Software Versions:

from Software Version

SCI1050S305 Version 4.06

SCI1051S305 Version 2.06

Installation and Operation

Manual DV14307.03

Issue 03 December 2015

Article-No. 0638.404-071

Preface

Dear Customer,

Thank you for purchasing BECKER products.

We are pleased that you have chosen our product and we are confident that it will meet your expectations.

For development of our product, the guidelines for highest quality and reliability have been borne in mind, supplemented by selection of high quality material, responsible production and testing in accordance to the ISO 9001 and DIN EN 9100 standards.

Our competent customer support department will respond on any technical question you may have.

Please do not hesitate to contact us at any time.

VHF-Transceiver Family



AR6201 (Single Block Transceiver)



RCU6201 (Remote Control Unit)



AR6203 (Single Block Transceiver)



RT6201 (Remote Transceiver)

First Issue and Changes			
Issue 03 December 2015			
LIST OF EFFECTIVE PAGES			
Page No.:	Date:	Page No.:	Date:
Cover Page	12/2015		
Introduction	12/2015		
Chapter 1 - 4	12/2015		

DV14307.03 / Article Number 0638.404-071

©2015 by Becker Avionics GmbH / all rights reserved

Table of Contents

1. General Description.....	11
1.1. Introduction.....	12
1.2. Purpose of Equipment.....	13
1.3. General Notes.....	13
1.4. Variants Overview.....	14
1.4.1. <i>Software Status</i>	16
1.5. Short Description.....	16
1.5.1. AR6201 Single Block Transceiver.....	16
1.5.2. RT6201 Remote Transceiver.....	17
1.5.3. RCU6201 Remote Control Unit.....	17
1.5.4. AR6203 Single Block Transceiver.....	18
1.6. Features Overview.....	18
1.7. Technical Data.....	21
1.7.1. Power Supply Data.....	21
1.7.2. General Data.....	22
1.7.3. Dimensions & Weight.....	22
1.7.4. Receiver Data for AR620X and RT6201.....	23
1.7.5. Transmitter Data AR620X and RT6201.....	24
1.7.6. Emergency Operation.....	24
1.7.7. Environmental Qualification AR620X and RCU6201.....	25
1.7.8. Environmental Qualification RT6201.....	26
1.7.9. Software.....	27
1.7.10. Complex Hardware.....	27
1.7.11. Approvals.....	27
1.8. Order Code.....	30
1.8.1. 620X.....	30
1.8.2. Accessories.....	30
2. Installation.....	33
2.1. Limitations.....	33
2.2. Packaging, Transport, Storage.....	33
2.3. Device Assignment.....	34
2.3.1. Scope of Delivery.....	34
2.3.2. Additional Required Equipment.....	34
2.3.3. Type Plate.....	35
2.3.4. <i>Software/Firmware Status – Functionality</i>	35
2.4. Mechanical Installation.....	36
2.4.1. AR6201 and RCU6201 Installation (Back Panel Mounting).....	36
2.4.2. AR6203 Installation.....	39
2.4.3. RT6201 Installation.....	41
2.5. Electrical Interface.....	44
2.5.1. Connector and Pin Assignment (AR620X and RT6201).....	44
2.5.1.1. Inputs / Outputs.....	47
2.5.2. Connector and Pin Assignment (RCU6201).....	51
2.6. Installation and Configuration.....	52
2.7. Antenna Installation.....	53
2.8. Installation Setup.....	53
2.8.1. Start Installation Setup.....	54
2.8.2. Navigate between Pages.....	54
2.8.3. Store Setup Data.....	54
2.8.4. Leave Installation Setup.....	54
2.8.5. Adjust Volume Settings (VU Meter).....	54
2.8.6. Installation Setup Pages - Description.....	55
2.9. Factory Default Settings.....	68
2.10. Wiring Diagrams and Settings.....	70
2.10.1. Single Seat Glider.....	70
2.10.1.1. Installation Setup.....	70
2.10.1.2. Wiring Diagrams Single Seat Glider.....	71
2.10.1.3. Wiring Diagrams Single Seat Glider 5-pol DIN Jack.....	72
2.10.2. Twin Seat Motor Glider.....	73

2.10.2.1.	Installation Setup	73
2.10.2.2.	Wiring Diagram Twin Seat Motor Glider	74
2.10.3.	General Aviation (GA) Aircraft	75
2.10.3.1.	Installation Setup (using Standard Microphones)	75
2.10.3.2.	Wiring Diagram General Aviation GA Using Standard Microphones	76
2.10.4.	Individual Dual Headset Configuration (two IC Circuit)	77
2.10.4.1.	Installation Setup	77
2.10.4.2.	Wiring Diagram Individual Dual Headset Configuration - two IC Circuit	78
2.10.5.	Twin Seat with AR620X Tandem Configuration	79
2.10.5.1.	Installation Setup	79
2.10.5.2.	Wiring Diagram Twin Seat with AR620X Tandem Configuration	80
2.10.6.	Aircraft with four Seats (no TANDEM)	81
2.10.6.1.	Installation Setup	81
2.10.6.2.	Wiring Diagram Aircraft with four Seats - no TANDEM	82
2.10.7.	Installation with RT6201 and RCU6201	83
2.10.7.1.	Wiring Diagram with RT6201 and RCU6201	83
2.10.8.	Aircraft with Intercom System	84
2.10.8.1.	Installation Setup	84
2.10.8.2.	Wiring Diagram Aircraft with Intercom System unbalanced	85
2.10.8.3.	Wiring Diagram Aircraft with Intercom System Balanced	86
2.10.9.	Twin Seat with RT6201 Tandem Configuration	87
2.10.9.1.	Installation Setup	87
2.10.9.2.	Wiring Diagram Twin Seat with RT6201 Tandem Configuration	88
2.11.	Predesigned Cable Harness	89
2.11.1.	1K065 for General Aviation	89
2.11.2.	1K062 (Open Cable Ends)	89
2.12.	Retrofitting AR4201 with AR6201	89
2.12.1.	Pin Compatibility AR4201 - AR6201	90
2.12.2.	Dynamic Microphone Input	91
2.12.3.	Temperature Sensor	91
2.12.4.	RS-232 Interface	91
2.12.5.	AFCU/AGC/AFWB	92
2.12.6.	CPIN (if Installed)	92
2.12.7.	+13.75 V Switched (AR4201) - PWR_EVAL (AR6201)	92
2.13.	Post Installation Tests	92
2.13.1.	Mechanical Installation and Wiring Check	92
2.13.2.	Power Supply	92
2.13.3.	Receiver / Transmitter Operation	92
2.13.4.	Antenna Check	92
2.13.5.	Interference Check	92
2.13.6.	Flight Test Check	94
2.14.	Trouble Shooting	95
2.15.	Continued Airworthiness	96
3.	Operating Instructions	97
3.1.	Device Description	97
3.1.1.	Device Assignment	97
3.1.2.	Type Plate	97
3.2.	Controls and Indicators	99
3.3.	Start-Up	100
3.4.	Receive and Transmit Mode	100
3.4.1.	Receive Mode	100
3.4.2.	Transmit Mode	101
3.5.	Frequency Selection Modes	101
3.5.1.	Standard Mode	102
3.5.2.	Direct Tune Mode	103
3.5.3.	Channel Mode	104
3.5.3.1.	Select Channels:	104
3.5.4.	Frequency Storage Functions	105
3.5.4.1.	Store	105
3.5.5.	Automatic Storage Function	106
3.5.5.1.	Delete data:	106

3.5.6. Scan Mode	107
3.6. SQUELCH	108
3.7. RX Field Strength Indication.....	108
3.8. Channel Spacing Mode	108
3.9. Auxiliary Audio Input.....	109
3.10. Intercom Operation.....	109
3.11. VOX & Speaker Operation	110
3.12. Menus	110
3.12.1. Intercom Menu	110
3.12.2. Pilots Menu.....	112
3.13. Warning and Failure Indications.....	113
4. Index.....	116

List of Abbreviations

List of Abbreviations

FAA	Federal Aviation Administration
AC	Alternating Current
AF	Audio Frequency
AR	Airborne Radio
ATT	Attenuation
AUX	Auxiliary
AWG	American Wire Gauge
BNC	Bayonet Neill Concelman
CBIT	Continuous Built-In Test
CFG	Configuration
CH	Channel
CM	Chassis Module
COM	Communication
DC	Direct Current
EASA	European Aviation Safety Agency
EMI	Electro Magnetic Interference
ETSO	European Transmission System Operators
EUROCAE	European Organisation for Civil Aviation Equipment
GND	Ground (Aircraft Ground)
GPS	Global Positioning System
HMI	Human Machinery Interface
HIRF	High Intensity Radiated Fields
IC	Intercom
I&O	Installation & Operation
LCD	Liquid Crystal Display
MFD	Multi-Function Display
M&R	Maintenance & Repair
N/A	Not Applicable
NAV	Navigation
PBIT	Power-On Built In Test
PTT	Push To Talk
PWR	Power
RCU	Remote Control Unit
RSSI	Received Signal Strength Indication
RT	Remote Transceiver
RX	Receive
SQL	Squelch
SPKR	Speaker (Loudspeaker)
SRC	Source
SW	Software
TSO	Technical Standard Order

List of Abbreviations

TX	Transmit
VOX	Voice Operated IC Threshold
VHF	Very High Frequency
VDC	Voltage Direct Current
VSWR	Voltage Standing Wave Ratio
VU	Volume Unit

Units

Units

V	Volt
mV	Millivolt
A	Ampere
mA	Milliampere
W	Watt
mW	Milliwatt
kHz	Kilohertz
MHz	Megahertz
s	Second
dBm	Power ratio in Decibel
dB	Decibel
Ohm (Ω)	Resistor
kg	Kilogram
$^{\circ}$ C	Degree Celsius
mm	Millimetre
cm	Centimetre

General Safety Definitions



Indicates a hazardous situation which, if not avoided, will result in death or serious injury.



Indicates a hazardous situation which, if not avoided, could result in death or serious injury.



Indicates a hazardous situation which, if not avoided, could result in minor or moderate injury.



Is used to address practices not related to physical injury.



Safety instructions (or equivalent) signs indicate specific safety-related instructions or procedures.

Disposal

⚠ CAUTION

The packaging material is inflammable, if it is disposed of improperly by burning, lethal fumes may develop.

This product contains materials that fall under the special disposal regulation, which corresponds to the EC directive for dangerous disposal material. We recommend disposing of the respective materials in accordance with the respectively valid environmental laws. The following table states the materials suitable for recycling and the materials which have to be disposed of separately.

Material	Suitable for recycling	Disposal
Metal	yes	no
Plastics	yes	no
Circuit boards	no	yes

Dispose of the circuit boards:

- Disposal via a technical waste dump which is allowed to take on e.g. electrolytic aluminium capacitors. Do under no circumstances dump the circuit boards with normal waste dump.

Warranty Conditions

User Conversions and Changes are Not Permitted

Any change made by the user excludes any liability on our part (excluding updates for the navigation data base).

- The device must not be opened.
- Do not make any modifications to the device, except for those described in the manual.
- Make connections to the inputs, outputs and interfaces only in the manner described in the manual.
- Fix the devices according to the mounting instructions.
We cannot provide any guarantee for other mounting methods.

Conditions of Utilization

General introductory notes

With this device you bought a product which was manufactured and tested before delivery with the utmost care.

Please take your time to read the following notes which you ought to follow closely during installation and operation.

Unless, all claims under the warranty will become void and a reduced service life or even damages must be expected.

⚠ CAUTION

The user is responsible for protective covers and/or additional safety measures in order to prevent damages to persons and electric accidents.

Additional Conditions of Utilization

Please refer to "Limitations", page 33.

Non Warranty Clause

We checked the contents of this publication for compliance with the associated hard and software. We can, however, not exclude discrepancies and do therefore not accept any liability for the exact compliance. The information in this publication is regularly checked, necessary corrections will be part of the subsequent publications.

Blank Page

1. General Description

In this chapter you can read about:

1.1.	Introduction.....	12
1.2.	Purpose of Equipment.....	13
1.3.	General Notes	13
1.4.	Variants Overview	14
1.5.	Short Description.....	16
1.5.1.	AR6201 Single Block Transceiver	16
1.5.2.	RT6201 Remote Transceiver.....	17
1.5.3.	RCU6201 Remote Control Unit	17
1.5.4.	AR6203 Single Block Transceiver	18
1.6.	Features Overview	18
1.7.	Technical Data	21
1.7.1.	Power Supply Data	21
1.7.2.	General Data.....	22
1.7.3.	Dimensions & Weight.....	22
1.7.4.	Receiver Data for AR620X and RT6201.....	23
1.7.5.	Transmitter Data AR620X and RT6201	24
1.7.6.	Emergency Operation	24
1.7.7.	Environmental Qualification AR620X and RCU6201.....	25
1.7.8.	Environmental Qualification RT6201	26
1.7.9.	Software.....	27
1.7.10.	Complex Hardware	27
1.7.11.	Approvals	27
1.8.	Order Code.....	30
1.8.1.	620X.....	30
1.8.2.	Accessories.....	30

This manual describes the operation and installation of the RCU-, RT-, AR6201 and AR6203 VHF Transceiver Family equipment. The ID label on your device shows the part number for identification purposes.

Before starting operation of the unit(s) please read this manual carefully, with particular attention to the description referring to your device(s). This manual also contains several optional elements of the system (second controller for example), that may not be contained in your delivery package and in that case are not applicable.

1.1. Introduction

AR-, RT-, RCU620X VHF Transceivers are a modern family of communication equipment that have comprehensive capabilities and significantly extend the typical aeronautical transceivers.

Despite its small size and weight the devices include inter alia:

- Sensitive receiver which meets the most recent requirements of ED-23C, including the ability to work in the offset-carrier (climax) operation in 25 kHz and 8.33 kHz channel spacing (class H2).
- Receiver includes SCAN (dual watch) mode. This allows simultaneous monitoring of two different VHF frequency channels without interrupting communication on the active frequency.
- High efficiency transmitter, which delivers more than 10 W modulated, or un-modulated, output power at 28 V supply voltage, or 6 W at 12 V. Lower power consumption allows longer operation from battery.
- Extended built-in intercom which can work as:
 - 4-way intercom with isolation mode – passengers could continue conversation or listening to music from MP3 player at the same time as pilots talk via intercom or communicate with the tower.
 - 2-way intercom for tandem operation – pilot and co-pilot work with separate controllers and can control their individual audio parameters, like volume or VOX. This mode is preferred especially for training due to full synchronization of LCD contents.
- Non-volatile memory for storing:
 - 99 channels can be labelled manually for storage of VHF frequencies.
 - 9 recently selected VHF frequencies are automatically stored.

For further descriptions we are using following terms for VHF transceivers, VHF remote transceiver and remote control unit, instead writing their complete model number.

620X in general for the device family.

AR620X for: AR6201, AR6203 (Single Block Transceiver).

RT for: RT6201 (Remote Transceiver).

RCU for: RCU6201 (Remote Control Unit).

The manuals "Maintenance and Repair" (M&R), "Installation and Operation (I&O) and "Operation Instructions" (OI) contain the following sections:

Section		DV 14307.04 M&R	DV 14307.03 I&O	OI
	General	X	X	N/A
	Installation	X	X	N/A
	Operation	X	X	X
	Theory of Operation	X	N/A	N/A
	Maintenance and Repair	X	N/A	N/A
	Illustrated Parts List	X	N/A	N/A
	Modification and Changes	X	N/A	N/A
	Circuit Diagrams	X	N/A	N/A
	Certifications	X	N/A	N/A
	Attachments	X	N/A	N/A

1.2. Purpose of Equipment

The 620X transceiver family enable voice communication between aircraft or between aircraft and ground using the very high frequency band between 118.000...136.9916 MHz respectively 136.9750 MHz with a selectable channel spacing of 25 kHz respectively 8.33 kHz. The wide scope of accessories also allows usage of the 620X VHF transceivers in ground-based applications.

The 620X Family is dedicated to applications where low power consumption is required. They are capable to operate from standard 14 VDC and 28 VDC installations and from 12 VDC or 24 VDC batteries.

Ultra low power consumption with extremely wide DC supply voltage range as well as compact and lightweight design allows application for gliders and leisure aircraft up to 2000 kg and balloons.

Built-in 4-seat configurable intercom, transmitter output power up to 10 W and option for connection of two controllers in tandem configurations extends the flexibility of the 620X Family.

The 620X transceivers also provide additional options such as:

- Intercom functionality for voice communication between aircraft crew and passengers
- Squelch functionality that automatically mutes receiver audio signal until clear signal is received to avoid unwanted audio noise
- Scan functionality for simultaneous monitoring of two VHF channels (receive mode)
- AUX audio input for connection of additional audio devices like navigation receiver, warning-tone generator, or MP3 music player.
- VHF channel database for easy access to predefined frequency channels
- Tandem functionality for synchronized operation of two controllers

1.3. General Notes

The word "frequency" also used in the sense of "channel name", as defined in EUROCAE, document ED-23B chapter 1.3.2.

In this document the word "memory channel" or "channel" means a memory place identified by a channel number, where a frequency may be stored for later use.

1.4. Variants Overview

Within the part number, the meaning of "- (XXX)" is:

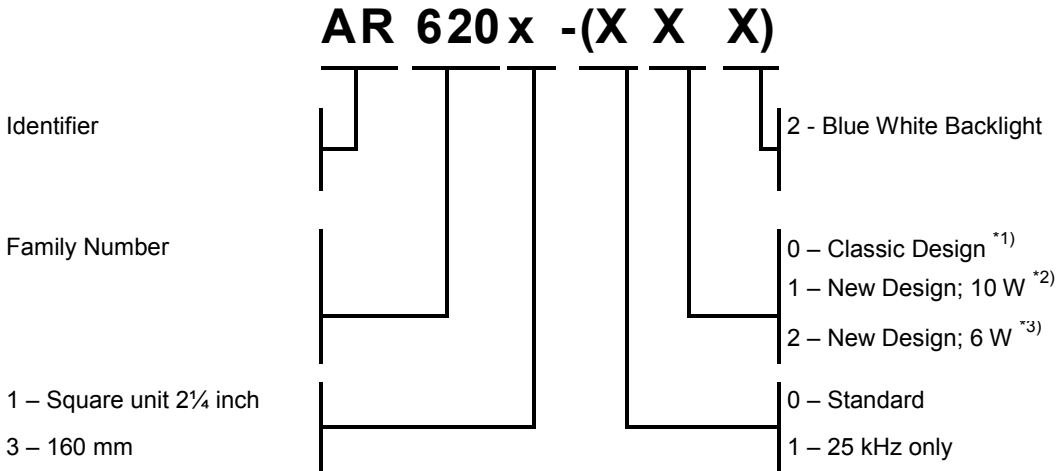

Note:

^{*1)} TX = 6 W; 2-seat IC

^{*2)} TX = 10 W; 4 seat IC; Tandem capability; lower mounting depth.

^{*3)} TX = 6 W; 4 seat IC; Tandem capability; lower mounting depth.

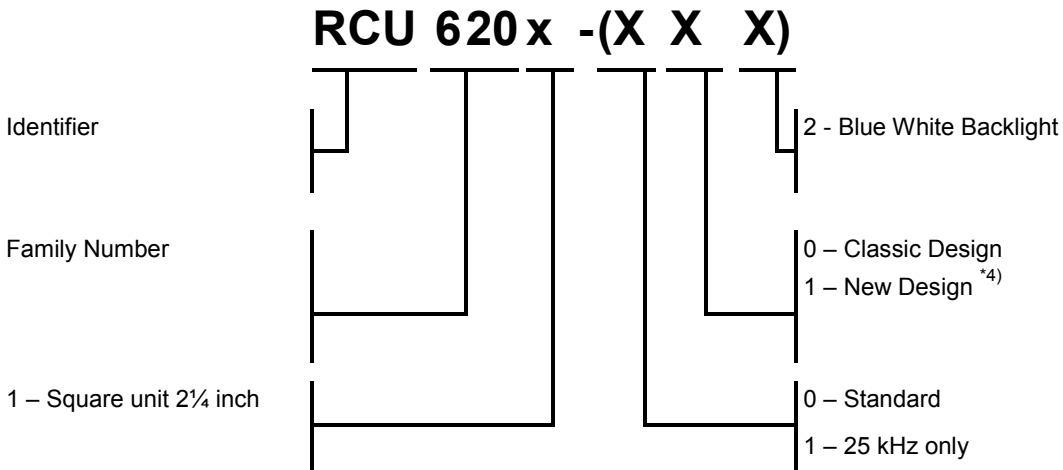

^{*4)} lower mounting depth.

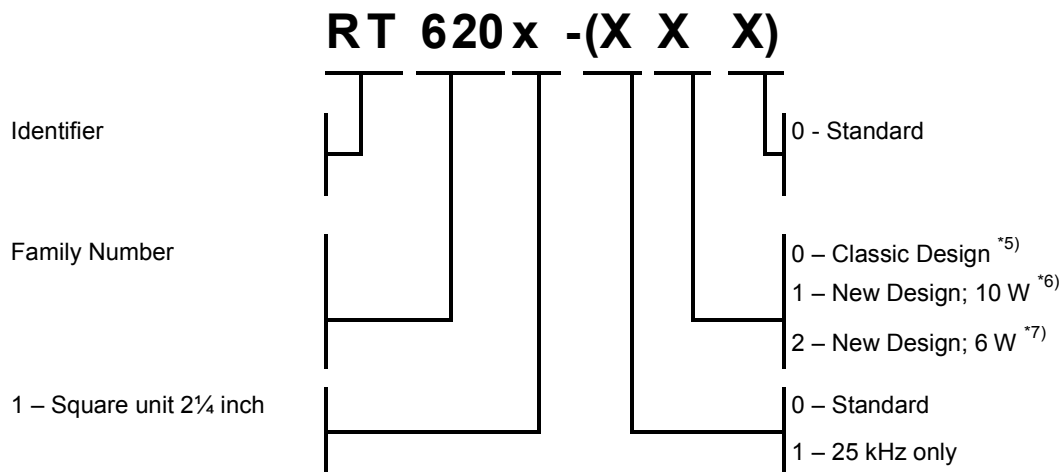

Note:

^{*5)} TX = 6 W; 2-seat IC

^{*6)} TX = 10 W; 4 seat IC; Tandem capability; lower mounting depth.

^{*7)} TX = 6 W; 4 seat IC; Tandem capability; lower mounting depth.

(0XX) indicates 8.33/25 kHz channel spacing capability

(1XX) indicates only 25 kHz channel spacing capability

(X1X) indicates transmit power $\geq 6\text{ W @ }14\text{ V}$ and $10\text{ W @ }28\text{ V}$

(X2X) indicates transmit power $\geq 6\text{ W @ }14\text{ V}$ and $6\text{ W @ }28\text{ V}$

(XX2) indicates white illumination colour on a black panel

AR6201 Single Block Transceiver

Part Number	Article No	8.33 kHz Mode	25 kHz Mode	Transmit PWR
AR6201-(012)	0631.418-910	yes	yes	$\geq 6\text{ W @ }14\text{ V}$ / $10\text{ W @ }28\text{ V}$
AR6201-(022)	0636.339-910	yes	yes	$\geq 6\text{ W @ }14\text{ V}$ / $6\text{ W @ }28\text{ V}$
AR6201-(112)	0631.434-910	no	yes	$\geq 6\text{ W @ }14\text{ V}$ / $10\text{ W @ }28\text{ V}$
AR6201-(122)	0636.355-910	no	yes	$\geq 6\text{ W @ }14\text{ V}$ / $6\text{ W @ }28\text{ V}$

RT6201 Remote Transceiver

Part Number	Article No	8.33 kHz Mode	25 kHz Mode	Transmit PWR
RT6201-(010)	0631.442-910	yes	yes	$\geq 6\text{ W @ }14\text{ V}$ / $10\text{ W @ }28\text{ V}$
RT6201-(020)	0636.312-910	yes	yes	$\geq 6\text{ W @ }14\text{ V}$ / $6\text{ W @ }28\text{ V}$
RT6201-(110)	0638.609-910	no	yes	$\geq 6\text{ W @ }14\text{ V}$ / $10\text{ W @ }28\text{ V}$
RT6201-(120)	0638.617-910	no	yes	$\geq 6\text{ W @ }14\text{ V}$ / $6\text{ W @ }28\text{ V}$

RCU6201 Remote Control Unit

Part Number	Article No	8.33 kHz Mode	25 kHz Mode	Transmit PWR
RCU6201-(012)	0631.469-910	yes	yes	N/A
RCU6201-(112)	0631.485-910	no	yes	N/A

AR6203 Single Block Transceiver

Part Number	Article No	8.33 kHz Mode	25 kHz Mode	Transmit PWR
AR6203-(012)	0630.993-910	yes	yes	≥ 6 W @ 14 V / 10 W @ 28 V
AR6203-(022)	0636.371-910	yes	yes	≥ 6 W @ 14 V / 6 W @ 28 V
AR6203-(112)	0631.566-910	no	yes	≥ 6 W @ 14 V / 10 W @ 28 V
AR6203-(122)	0636.398-910	no	yes	≥ 6 W @ 14 V / 6 W @ 28 V

1.4.1. Software Status

Description see "Software/Firmware Status – Functionality", page 35.

1.5. Short Description

For a "Side by Side" seat configuration, the following combinations apply:

- AR6201 or AR6203 Single Block Transceiver.
- RT6201 Remote Transceiver with Remote Control Unit (RCU6201).

For a "Tandem" seat configuration, the following combinations apply:

- AR6201 or AR6203 Single Block Transceiver with additional Remote Control Unit (RCU6201).
- RT6201 Remote Transceiver with Remote Control Unit (RCU6201) and additional second Remote Control Unit (RCU6201).

In tandem configuration two controllers and one transceiver are connected. Tandem configuration is useful for training purposes where pilot and student have their own controller with full-synchronized views or as separate controllers for pilot and co-pilot.

1.5.1. AR6201 Single Block Transceiver

The AR6201 is a compact and lightweight unit designed for operation in a cockpit environment for both general aviation aircraft and helicopters. All controls and indicators are located on the front panel. The equipment connectors and the antenna socket are located at the rear of the unit.

Installation via four screws (rear panel installation). The dimensions correspond to the standard instrument diameter of 58 mm (2¼ inch).



Figure 1-1: AR6201 Single Block Transceiver

1.5.2. RT6201 Remote Transceiver

The RT6201 is a compact and lightweight single block unit in rectangular shape that contains a VHF transceiver. The RT6201 requires a dedicated Remote Control Unit RCU6201 or a third party controller, e.g. a Multi Function Display (MFD), by means of the Becker proprietary protocol.

Installation via four screws using the attached mounting equipment. The dimensions correspond to the standard instrument diameter of 58 mm (2¼ inch). To meet the conditions for certification use the mounting method with mounting kit MK6201-(010).

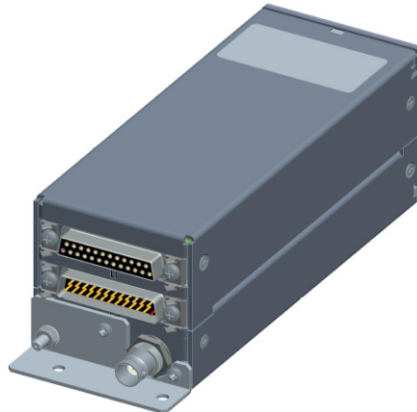

Figure 1-2: RT6201 Single Block Remote Transceiver

1.5.3. RCU6201 Remote Control Unit

The RCU6201 is a compact and lightweight unit. All controls and indicators are located on the front panel. The equipment connectors are located at the rear of the unit.

Installation via four screws (rear panel installation). The dimensions correspond to the standard instrument diameter of 58 mm (2¼ inch).



Figure 1-3: RCU6201 Remote Control Unit

1.5.4. AR6203 Single Block Transceiver

The AR6203 is a single block unit, designed for operation in a cockpit environment for both, general aviation aircraft and helicopters. All controls and indicators are located on the front panel. The equipment connectors and the antenna socket are located at the rear of the unit.

The AR6203 should be mounted with the designated mounting kit MK6403-1 (see "AR6203 Installation", page 39). Holes on both sides of the mounting kit frame enable the device been mounted in the aircraft cockpit.

The dimensions correspond to the state-of-the-art 160 mm (6.3") panel mounted design.



Figure 1-4: AR6203 Single Block Transceiver

1.6. Features Overview

Frequency Indication

A liquid crystal display (LCD) provides frequency indication. The required operating frequency is selectable by means of a "ROTARY ENCODER". The relation between the real operating frequency and the displayed frequency complies with the standards (ED-23B, chapter 1.3.2). For an overview, refer to the table below.

Operating Frequency MHz	Channel Spacing kHz	Displayed Frequency	
		8.33 + 25 kHz mixed Mode	25 kHz Mode
118.0000	25	118.000	118.00
118.0000	8.33	118.005	N/A
118.0083	8.33	118.010	N/A
118.0166	8.33	118.015	N/A
118.0250	25	118.025	118.02
etc.	etc.	etc.	etc.
136.9750	25	136.975	136.97
136.9750	8.33	136.980	N/A
136.9833	8.33	136.985	N/A
136.9916	8.33	136.990	N/A

Audio Outputs

The 620X transceiver includes four fully configurable outputs:

- Headphone 1 output, rated output power is 300 mW into 75 Ω .
- Headphone 2 output, rated output power is 200 mW into 75 Ω .
- Speaker output, rated output power is 4 W into 4 Ω .
- LINE-OUT output intended for ground station use only

Note: **Headphone 2 and speaker output cannot be active at the same time**

Mike Inputs

The VHF transceiver has an input for dynamic microphone (DYN_MIKE) and an input for standard microphone (STD_MIKE).

The 620X transceiver provides four microphone inputs:

- Standard microphone input 1 (STD_MIKE1)
- Standard microphone input 2 (STD_MIKE2)
- Standard microphone input 3 (STD_MIKE3)
- Dynamic microphone input (DYN_MIKE)

Each input is able to operate with one single microphone or with two microphones of the same type connected in parallel.

AF Auxiliary Input

The AF auxiliary provides the interface to connect an external audio source (e.g. NAV, music-player) to the transceiver. Interconnection of multiple external audio sources on this particular port requires additional external decoupling/isolation resistors. The external audio is audible only when the transceiver is in receiving mode.

The individual audio volume is set directly at the particular external equipment.

Side Tone

The side tone is available on the headphone output during transmission. The side tone volume automatically adapts to the intercom volume setting.

Squelch Operation

When enabled the squelch (muting) circuit suppresses weak signals. There are two kinds of squelch methods implemented, carrier- and noise-squelch. Carrier-squelch depends on the received signal strength and is adjustable in installation setup; the noise-squelch depends on the detected noise level and is adjustable in the pilot setup.

Memory Channels

The memory function allows storage of up to 99+9 frequencies. This memory may contain up to 99 frequencies stored manually. A user defined text label is assignable for each stored frequency. Additionally the last recently used 9 (active) frequencies are stored automatically as "LAST" channels.

Intercom Operation

The built-in intercom circuit provides internal communication via between pilots and passengers via connected headsets. The 620X system has two intercom circuits, "Front row" and "Back row". You can connect a maximum of four headsets, e.g. pilot & co-pilot to first circuit and two passengers to second circuit).

Scan Mode

Scan mode provides a dual watch function. The device is capable of monitoring frequencies on two different channels, active & preset simultaneously. The signal of the active frequency will always be audible, since it will have priority at all times.

Tandem Operation

Tandem mode enables operation of two controllers simultaneously. The controllers synchronizing each other in such a way, that both display the same information.

Illumination

The illumination of LCD and push buttons can be controlled either directly from the front panel via the pilots menu or externally via the dimming input lines. If external dimming selected, the illumination curve (brightness to voltage relation) is adjustable in installation setup.

LOW BATT Indication

The transceiver monitors power supply voltage. If the supply voltage drops below the adjustable threshold, the display indicates the message "LOW BATT". If the power supply voltage drops further, emergency operation mode activates.

Emergency Operation

If the power supply voltage drops below 10.25 V, the transceiver continues operation with degraded performance. If power supply further drops below 9.0 Volt, the unit automatically switches off.

Built-in Tests PBIT and CBIT

After power-up, the unit performs a self-test (power-up built-in test / PBIT). During PBIT, the transceiver displays "WAIT" and additionally the corresponding software versions of both, the control head and chassis module become visible.

If faults are detected during PBIT, the error message "FAILURE, press any key" is displayed. If no faults are detected the transceiver automatically activates the last active mode set at last power-off.

During normal operation, a continuous built-in test (CBIT) permanently verifies the correct operation of the unit. If detecting a problem during CBIT an error message become displayed.

Installation Setup

Configuration of the installation parameters such as mike sensitivity, mike type selection, speaker enable/disable and several other parameters, via the installation setup provided.

Service Mode

The service mode is a special configuration mode accessible via RS422 interface with a proprietary serial data communication protocol. This mode is for use by authorized maintenance organizations during aircraft service on ground only.

1.7. Technical Data

1.7.1. Power Supply Data

Technical characteristics 620X	
Nominal supply voltage range	11.0...30.3 V
Extended supply voltage range	10.25...32.2 V
Emergency operation	9.0...10.25 V
Dimming control	0...14 V or 0...28 V

Typical Power Consumption

Technical characteristics					
	AR620X (X2X) 6 W	AR620X (X1X) 10 W	RT6201 (X2X) 6 W	RT6201 (X1X) 10 W	RCU6201 (XXX)
Power "off" @ 12 VDC	≤ 0.10 mA	≤ 0.10 mA	≤ 0.10 mA	≤ 0.10 mA	≤ 0.10 mA
Power "off" @ 27.5 VDC	≤ 0.10 mA	≤ 0.10 mA	≤ 0.10 mA	≤ 0.10 mA	≤ 0.10 mA
Reception stand-by mode @ 13.75 VDC, panel backlight off	≤ 140 mA	≤ 140 mA	≤ 120 mA	≤ 120 mA	≤ 20 mA
Reception stand-by mode @ 27.5 VDC, panel backlight off	≤ 80 mA	≤ 80 mA	≤ 80 mA	≤ 80 mA	≤ 20 mA
Transmit mode (in %) @ 13.75 VDC, VSWR=1:1	1.8 A at 70% 1.5 A at 0%	-	1.8 A at 70% 1.5 A at 0%	-	≤ 0 mA
Transmit mode @ 27.5 VDC, VSWR=1:1	1.2 A at 70% 1.0 A at 0%	1.4 A at 70% 1.0 A at 0%	1.2 A at 70% 1.0 A at 0%	1.4 A at 70% 1.0 A at 0%	≤ 20 mA
Absolute maximum current @ 13.75 VDC, VSWR=3:1	≤ 3 A	-	≤ 2,9 A	-	≤ 20 mA
Absolute maximum current @ 27.5 VDC, VSWR=3:1	≤ 2 A	≤ 2.5 A	≤ 1.9 A	≤ 2.4 A	≤ 20 mA

1.7.2. General Data

For 620X devices the following data apply:

Technical characteristics 620X		Model
Frequency range	118.000...136.975 MHz	(-1XX model)
	118.000...136.9916 MHz	(-0XX model)
Channel spacing	25 kHz	(-1XX model)
	8.33/25 kHz	(-0XX model)
Number of channels	760	(-1XX model)
	2280 +760	(-0XX model)
Storage Temperature range	-55...+85 °C	all versions
Operating Temperature range	-20...+55 °C	AR620X-(XXX), RCU6201-(XXX)
	-40...+55 °C	RT6201-(XXX)
	short-time +70 °C	all versions
Operating Altitude	35 000 ft	
Vibration	Category S (Curve M) + Category U (Curve G)	

1.7.3. Dimensions & Weight

	AR6201-(XXX)	AR6203-(XXX)	RCU6201-(XXX)	RT6201-(XXX)
Front panel (W x H)	61 x 61 mm (2.4 x 2.4 inch)	158.8 x 41.2 mm (6.25 x 1.62 inch)	61 x 61 mm (2.4 x 2.4 inch)	61 x 61 mm (2.4 x 2.4 inch)
Depth of unit	205.7 mm (8.98 inch)	224.4 mm (8.83 inch)	65.9 mm (2.59 inch)	188 mm (7.4 inch)
Mounting depth	184.8 mm (7.28 inch)	224.4 mm (8.83 inch)	39.3 mm (1.55 inch)	188 mm (7.4 inch)
Mounting	Back panel standard Ø58 mm (2¼ inch)	Mounting kit MK6403-1 panel mount 160 mm (6.3 inch)	Back panel standard Ø58 mm (2¼ inch)	Mounting kit MK6201-(010) or directly on avionic bay*
Material	AlMg/Plastic	AlMg/Plastic	AlMg/Plastic	AlMg
Surface treatment	Control-head coated with black matt paint			
Weight	675 g (1.488 lbs)	800 g (1.763 lbs)	200 g (0.44 lbs)	600 g (1.32 lbs)

Note:

*Use the mounting method with mounting kit to meet the conditions for certification.

1.7.4. Receiver Data for AR620X and RT6201

Technical characteristics AR620X, RT6201	
Sensitivity	≤ -101 dBm for a (S+N)/N ratio of 6 dB (nominal)
	≤ -93 dBm for a (S+N)/N ratio of 6 dB (qualified under environmental conditions)
Effective bandwidth (8.33 kHz channel spacing)	$\geq \pm 2.78$ kHz at the 6 dB points
	$\leq \pm 7.37$ kHz at the 60 dB points
Effective bandwidth (25 kHz channel spacing)	$\geq \pm 8$ kHz at the 6 dB points
	$\leq \pm 22$ kHz at the 60 dB points
Squelch	level adjustable
AGC characteristic	≤ 6 dB in range -93 dBm...0
Distortion	$\leq 15\%$ at 30% 10 dB below rated output power
	$\leq 15\%$ at 70% and rated output power
Audio frequency response (8.33 kHz channel spacing)	≤ 6 dB 350...2500 Hz
	≥ 35 dB at 4000 Hz
Audio Noise	≤ 6 dB 300...3400 Hz
	≥ 18 dB at 4000 Hz
Rated output power for speaker operation	≥ 4 W into 4 Ω
Rated output power for headphone 1	≥ 300 mW into 75 Ω
	≥ 100 mW into 600 Ω
Rated output power for headphone 2	≥ 200 mW into 75 Ω
	≥ 100 mW into 600 Ω
Audio auxiliary input	50 mV...8 V (adjustable) across 600 Ω
Offset-carrier operation	YES (25/8.33 kHz)

1.7.5. Transmitter Data AR620X and RT6201

Technical characteristics AR620X, RT6201	
Output power into 50 Ω (with and without modulation)	≥ 6 W for AR620X-(X2X) and RT6201-(X2X)
	≥ 10 W for AR620X-(X1X) and RT6201-(X1X)
Frequency tolerance	≤ ±5 ppm
Duty cycle	120 s (TX); 480 s (RX)
Type of modulation	A3E
Modulation capability	≥ 70%
Distortion	≤ 15%
Audio frequency response (8.33 kHz channel spacing)	≤ 6 dB, 350...2500 Hz
Audio frequency response (25 kHz channel spacing)	≤ 6 dB, 300...2500 Hz
Dynamic microphone	1...20 mV compressor starting point, adjustable
(with compressor)	Input balanced, 200 Ω Input range up to 20 dB above compressor starting point.
Standard microphone(s)	10...1000 mV compressor starting point, adjustable
(with compressor)	Input unbalanced, 150 Ω Input range up to 20 dB above compressor starting point.
FM deviation with modulation	≤ 3 kHz
Sidetone	adjustable
Automatic shutdown of transmit mode	120 s
	(Factory configurable 30...120 s)

1.7.6. Emergency Operation

SAFETY INSTRUCTIONS

For power-supply voltages below 10.25 V, the speaker output of the transceiver will automatically switch "OFF" without further indication.

If the device enters emergency operation, the speaker is switched "OFF" due to degraded performance. Depending on settings in installation setup "LOW BATT" may be indicated if supply voltage drops below a predefined threshold to indicate to the user, that he should connect his headset as the speaker may be switched "OFF" soon). In this case, a headset is required to continue operation of the transceiver. This data is applicable for AR620X and RCU6201.

Technical characteristics	
Panel & Display Backlight	switched off
TX Output Power	≥ 2 W into 50 Ω (with modulation)
TX Modulation Depth	≥ 50%
RX Sensitivity	≤ -93 dBm for a (S+N)/N ratio of 6 dB

1.7.7. Environmental Qualification AR620X and RCU6201

Under environmental test, condition in accordance with the procedures set forth in EUROCAE/RTCA Document ED-14F/DO-160F following performance has been demonstrated.

Condition	Section	Cat.	Description
Temperature and Altitude	4.0	C4	
Ground Survival Low Temperature	4.5.1	C4	-55 deg C
Short-Time Operating Low Temperature			-20 deg C
Low Operating Temperature			-20 deg C
High Ground Survival Temperature	4.5.2		+85 deg C
High Short-Time Operating Temp.			+70 deg C
High Operating Temp.			+55 deg C
In-flight Loss of Cooling	4.5.5	-	No forced cooling required
Altitude	4.6.1	C4	35000 ft
Decompression	4.6.2		N/A
Overpressure	4.6.3		N/A
Temperature Variation	5.0	B	5 deg C per minute
Humidity	6.0	A	Standard
Shock and Crash Safety	7.0	B	Fixed-wing and Helicopter, standard
Vibration	8.0	S+U	Test curve M+G Fixed-wing + Helicopter
Explosion Proofness	9.0	-	N/A
Water Proofness	10.0	Y	-
Fluids Susceptibility	11.0	-	N/A
Sand and Dust	12.0	-	N/A
Fungus Resistance	13.0	-	N/A
Salt Spray	14.0	-	N/A
Magnetic Effect	15.0	Z	1 degree deflection at 0.3 m
Power Input	16.0	B	DC installations with battery of significant capacity
Voltage Spike	17.0	A	High degree of protections against voltage spikes
Audio Freq. Conducted Susceptibility	18.0	B	DC installations with battery of significant capacity
Induced Signal Susceptibility	19.0	AC	Primary power DC or AC, 400 Hz

Condition	Section	Cat.	Description
Radio Frequency Susceptibility	20.0	RW	Interim high intensity radiated fields
Emission of Radio Frequency Energy	21.0	B	Equipment where interference should be controlled to a tolerable level
Lightning Induced Transients Susceptibility	22.0	A1E3X	Pin test waveform A, level 3 Cable bundle test waveform E, level 3
Lightning Direct Effects	23.0	-	N/A
Icing	24.0	-	N/A
Electrostatic Discharge	25.0	A	Equipment operated in an aerospace environment
Fire, Flammability	26.0	-	N/A

1.7.8. Environmental Qualification RT6201

Under environmental test, condition in accordance with the procedures set forth in EUROCAE/RTCA Document ED-14F/DO-160F following performance has been demonstrated.

Condition	Section	Cat.	Description
Temperature and Altitude	4.0	C4	
Ground Survival Low Temperature	4.5.1	C4	-55 deg C
Short-Time Operating Low Temperature			-40 deg C
Low Operating Temperature			-40 deg C
High Ground Survival Temperature	4.5.2		+85 deg C
High Short-Time Operating Temp.			+70 deg C
High Operating Temp.			+55 deg C
In-flight Loss of Cooling	4.5.5	-	No forced cooling required
Altitude	4.6.1	C4	3500 ft
Decompression	4.6.2		N/A
Overpressure	4.6.3		N/A
Temperature Variation	5.0	B	5 deg C per minute
Humidity	6.0	A	Standard
Shock and Crash Safety	7.0	B	Fixed-wing and Helicopter, standard
Vibration	8.0	S+U	Test curve M+G fixed-wing + helicopter
Explosion Proofness	9.0	-	N/A
Water Proofness	10.0	Y	N/A
Fluids Susceptibility	11.0	-	N/A
Sand and Dust	12.0	-	N/A
Fungus Resistance	13.0	-	N/A
Salt Spray	14.0	-	N/A
Magnetic Effect	15.0	Z	1 degree deflection at 0.3 m
Power Input	16.0	B	DC installations with battery of significant capacity

Condition	Section	Cat.	Description
Voltage Spike	17.0	A	High degree of protections against voltage spikes
Audio Freq. Conducted Susceptibility	18.0	B	DC installations with battery of significant capacity
Induced Signal Susceptibility	19.0	AC	Primary power DC or AC, 400 Hz
Radio Frequency Susceptibility	20.0	SW	Interim High Intensity Radiated Fields
Emission of Radio Frequency Energy	21.0	B	Equipment where interference should be controlled to a tolerable level
Lightning Induced Transients Susceptibility	22.0	A1E3X	Pin test waveform A, level 3 Cable bundle test waveform E, level 3
Lightning Direct Effects	23.0	-	N/A
Icing	24.0	-	N/A
Electrostatic Discharge	25.0	A	Equipment operated in an aerospace environment
Fire, Flammability	26.0	-	N/A

1.7.9. Software

The design and development processes used for AR6201 family software are in compliance with the rules given in EUROCAE/RTCA Document ED-12B/DO-178B; "Software Considerations in Airborne System and Equipment Certification". Hereby 'Design Assurance Level' (DAL) "C" was followed and the complete software documentation is based on this level.

Nevertheless, Becker claimed for AR6201 family software in accordance with EUROCAE/RTCA Document ED-12B/DO-178B the **Design Assurance Level D**.

Refer to AC 23.1309-1D and/or AC 23.1309-1E to see limitations for installations into aircrafts.

The conditions and tests required for TSO approval of this article are minimum performance standards. It is the responsibility of those installing this article either on or within a specific type or class of aircraft to determine that the aircraft installation conditions are within the TSO standards. TSO articles must have separate approval for installation in an aircraft. The article may be installed only in compliance with 14 CFR part 43 or the applicable airworthiness requirements.

1.7.10. Complex Hardware

The 620X devices do not contain complex hardware.

1.7.11. Approvals

SAFETY INSTRUCTIONS

Unauthorized changes or modifications to the 620X transceiver may void the compliance to the required regulatory agencies and authorization for continued equipment usage.

AR6201 Single Block Transceiver

Part Number	Article Number	EASA Approval	TSO Conformity	FCC Approval
AR6201-(012)	0631.418-910	EASA.210.1249 ETSO-2C37e Class: D, E ETSO-2C38e Class: 4, 6	TSO-C169a Class: D, E, 4, 6	B54AR6201
AR6201-(112)	0631.434-910	EASA.210.1249 ETSO-2C37e Class: D ETSO-2C38e Class: 4	TSO-C169a Class: D, 4	B54AR6201
AR6201-(022)	0636.339-910	EASA.210.1249 ETSO-2C37e ETSO-2C38e Class: D, E, 4, 6	TSO-C169a Class: D, E, 4, 6	B54AR6201
AR6201-(122)	0636.355-910	EASA.210.1249 ETSO-2C37e Class: D ETSO-2C38e Class: 4 Class: D, 4	TSO-C169a Class: D, 4	B54AR6201

RT6201 Remote Transceiver

Part Number	Article Number	EASA Approval	TSO Conformity	FCC Approval
RT6201-(010)	0631.442-910	EASA.210.1249 ETSO-2C37e Class: D, E ETSO-2C38e Class: 4, 6	TSO-C169a Class: D, E, 4, 6	pending
RT6201-(020)	0636.312-910			

RCU6201 Remote Control Unit

Part Number	Article Number	EASA Approval	TSO Conformity	FCC Approval
RCU6201-(012)	0631.469-910	EASA.210.1249 ETSO-2C37e Class: D, E ETSO-2C38e Class: 4, 6	TSO-C169a Class: D, E, 4, 6	B54AR6201
RCU6201-(112)	0631.485-910	EASA.210.1249 ETSO-2C37e Class: D ETSO-2C38e Class: 4	TSO-C169a Class: D, 4	B54AR6201

AR6203 Single Block Transceiver

Part Number	Article Number	EASA Approval	TSO Conformity	FCC Approval
AR6203-(012)	0630.993-910	EASA.210.10054849 ETSO-2C169a Class: C, H2, 4, 6	TSO-C169a Class: D, E, 4, 6	pending
AR6203-(112)	0631.566-910	EASA.210.10054849 ETSO-2C169a Class: C, 4	TSO-C169a Class: C, 4	pending
AR6203-(022)	0636.371-910	EASA.210.10054849 ETSO-2C169a Class: C, H2, 4, 6	TSO-C169a Class: D, E, 4, 6	pending
AR6203-(122)	0636.398-910	EASA.210.10054849 ETSO-2C169a Class: C, 4	TSO-C169a Class: C, 4	pending

1.8. Order Code

1.8.1. 620X

Qty	AR6201 Single Block Transceiver	
1	AR6201-(012), 8.33/25 kHz, 10 W at 28 V	Article no. 0631.418-910
1	AR6201-(022), 8.33/25 kHz, 6 W at 12 V	Article-no. 0636.339-910
1	AR6201-(112), 25 kHz, 10 W at 28 V	Article-no. 0631.434-910
1	AR6201-(122), 25 kHz, 6 W at 12 V	Article-no. 0636.355-910

Qty	RT6201 Remote Transceiver	
1	RT6201-(010), 8.33/25 kHz, 10 W at 28 V	Article no. 0631.442-910
1	RT6201-(020), 8.33/25 kHz, 6 W at 12 V	Article-no. 0636.312-910
1	RT6201-(110), 25 kHz, 10 W at 28 V	Article-no. 0638.609-910
1	RT6201-(120), 25 kHz, 6 W at 12 V	Article-no. 0638.617-910

Qty	RCU6201 Remote Control Unit	
1	RCU6201-(012), 8.33/25 kHz	Article no. 0631.469-910
1	RCU6201-(112), 25 kHz	Article-no. 0631.485-910

Qty	AR6203 Single Block Transceiver	
1	AR6203-(012), 8.33/25 kHz, 10 W at 28 V	Article no. 0630.993-910
1	AR6203-(022), 8.33/25 kHz, 6 W at 12 V	Article-no. 0636.371-910
1	AR6203-(112), 25 kHz, 10 W at 28 V	Article-no. 0631.566-910
1	AR6203-(122), 25 kHz, 6 W at 12 V	Article-no. 0636.398-910

1.8.2. Accessories

Qty	Connector Kit	
1	CK4201-S (soldering version); <ul style="list-style-type: none"> Dsub 25-s, Connector housing, Antenna plug, Label "COMM" 	Article no. 0879.304-954
1	CK4201-C (crimp version); <ul style="list-style-type: none"> Dsub 25-c, Connector housing, Antenna plug, Label "COMM" 	Article no. 0514.901-954
1	CK6000-S (soldering version); <ul style="list-style-type: none"> Dsub Connector LE M 25pol, Connector housing 	Article no. 0640.621-954
1	CK6000-C (crimp version); <ul style="list-style-type: none"> Dsub Connector LE M 25pol, Connector housing 	Article no. 0640.611-954
1	CK6200-S (soldering version); <ul style="list-style-type: none"> Dsub25-s, Dsub25-p,2 Connector housings, Antenna plug, Label "COMM" 	Article no. 0617.903-954

Qty	Connector Kit	
1	CK6200-C (crimp version); <ul style="list-style-type: none"> Dsub25-s, Dsub25-p, 2 Connector housings, Antenna plug, Label "COMM", Coding key 	Article no.0617.891-954
1	CK5000-S (soldering version); <ul style="list-style-type: none"> Dsub15-s, Connector housing, Label "COMM", Label "NAV", Label "ADF", Label "XPDR" 	Article no. 0511.791-954
1	CK5000-C (crimp version); <ul style="list-style-type: none"> Dsub25-s, Connector housing, Label "COMM", Label "NAV", Label "ADF", Label "XPDR" 	Article no. 0511.781-954

Qty	Cable harness	
1	1K062 Cable harness AR62XX (open cable ends), length 3.7 m, for sailplanes, motor gliders, to be used for: <ul style="list-style-type: none"> Headphone Dynamic microphone Speaker PTT switch Power supply 	Article no. 0621.390-950
1	1K065 Cable harness AR62XX (prepared with connectors), length 3.7 m, for general aviation, to be used for: <ul style="list-style-type: none"> 2x Phone, jack socket PJ55 2x Standard microphone, jack socket PJ68 1x PTT switch 1x Audio in, jack socket 3.5 mm 1x Power supply 	Article no. 0621.455-950

For details please refer to "Predesigned Cable Harness", page 89.

Qty	Mounting	
1	Mounting Kit MK6201-(010)	Article no. 0631.515-261
1	Mounting Kit MK6403-1	Article no. 0598.569-284
1	Adapter for AR3201 wiring 1AD042	Article no. 0877.522-959

Qty	Available Documentation	
1	Operating Instructions AR620X, RT6201, RCU6201, English	Article no. 0638.420-071
1	Operating Instructions AR620X, RT6201, RCU6201, German	Article no. 0641.413-071
1	Manual Installation and Operation 620X Family, English	Article no. 0638.404-071
1	Manual Maintenance and Repair 620X Family, English	Article no. 0638.412-071

Blank Page

2. Installation

This manual must be available close to the device during the performance of all tasks.

The installation of the transceiver depends on the type of aircraft and its equipment. Therefore, this section only provides general information.

Careful planning should be applied to achieve the desired performance and reliability from the product. Any deviations from the installation instructions prescribed in this document shall be accomplished in accordance with the requirements set forth in FAA AC 43 (Federal Aviation Administration, Advisory Circular).

In this chapter you can read about:

2.1. Limitations	33
2.2. Packaging, Transport, Storage	33
2.3. Device Assignment	34
2.4. Mechanical Installation	36
2.5. Electrical Interface	44
2.6. Installation and Configuration	52
2.7. Antenna Installation	53
2.8. Installation Setup	53
2.9. Factory Default Settings	68
2.10. Wiring Diagrams and Settings	70
2.11. Predesigned Cable Harness	89
2.12. Retrofitting AR4201 with AR6201	89
2.13. Post Installation Tests	92
2.14. Trouble Shooting	95
2.15. Continued Airworthiness	96

2.1. Limitations

620X design allows installation in cockpit environment of general aviation aircraft including helicopters. Following limitations apply for the installation of the unit:

- Installations must be in accordance with appropriate EASA or FAA approved guidelines. The personnel installing this device must ensure that the aircraft installation conditions are within the ETSO/TSO standards applicable for the specific type or class of aircraft,
- The 620X transceiver must be connecting to a VHF antenna in order to satisfy FAA TSO-C169a.
- The conditions and tests for ETSO/TSO approval of this article are minimum performance standards.
- The equipment is not qualified for installation in areas where fluid contamination is quite likely.

SAFETY INSTRUCTIONS

Changes or modifications made to this equipment not expressly approved in written form by Becker may void the authorization to operate this equipment.

2.2. Packaging, Transport, Storage

Visually inspect the package contents for signs of transport damage.

Packaging Material and Transport

⚠ CAUTION

The packaging material is inflammable, if it is disposed of improperly by burning, lethal fumes may develop.

The packaging material can be kept and reused in the case of a return shipment. Improper or faulty packaging may lead to transport damages.

Make sure to transport the device always in a safe manner and with the aid of suitable lifting equipment if necessary. Do never use the electric connections for lifting. Before the transport, a clean, level surface should be prepared to place the device on. The electric connections may not be damaged when placing the device.

First Device Checkup

- Check the device for signs of transport damages.
- Please verify if the indications on the type plate correspond to your purchase order.
- Check if the equipment is complete ("Scope of Delivery", page 34).

Storage

If you do not wish to mount and install the device immediately, make sure to store it in a dry and clean environment. Make sure that the device is not stored near strong heat sources and that no metal chippings can get into the device.

2.3. Device Assignment

This manual is valid for the following devices:

- AR6201-(XX2)
- AR6203-(XX2)
- RT6201-(XX0) with RCU6201-(X12)

from Software Version

SCI1050S305 Version 4.06

SCI1051S305 Version 2.06

Details see "Variants Overview", page 14

2.3.1. Scope of Delivery

- Manuals
 - Operating Instructions.
- Device in accordance with your order.
- Device accessories
- Documents of Certifications if available

2.3.2. Additional Required Equipment

- Mounting kit MK6403-1 (for AR6203)
- Mounting kit MK6201-(10) (for RT6201 to meet the conditions for certification).
- Connector kits.
- Cable harness.

Details see "Order Code" page 30

2.3.3. Type Plate

The device type is defined by the type plate (on the housing):



Figure 2-1: Type plate (example)

Explanation:

PN:	<p>Type designation: AR6201 = Single Block VHF Transceiver 58 mm (2¼ inch) AR6203 = Single Block VHF Transceiver 160 mm (6.3 inch) RT6201 = Remote VHF Transceiver RCU6201 = Remote Control Unit 58 mm (2¼ inch)</p> <p>Options: 0XX: 8.33/25 kHz channel spacing capability 1XX: 25 kHz channel spacing capability only X1X: 6 W @ 14 V / 10 W at 28 V X2X: 6 W @ 14 V XX2: white illumination colour on black panel</p>
SN:	Unique number of the particular device
AN:	Article number
DoM:	Date of Manufacturing
	<p>Software: Corresponding to the displayed version</p>
	<p>Compliance and Certifications Corresponding to the displayed text and logos</p>

2.3.4. Software/Firmware Status – Functionality

The software version is displayed at the screen for a few seconds after power on.

Please contact our Customer Service for details about software modification updates.

2.4. Mechanical Installation

SAFETY INSTRUCTIONS

The device must not be opened.

When installing the device, make sure the heat dissipators of the device receive sufficient air. Keep an efficient distance of the devices with integrated ventilator fans in order to ensure free circulation of the cooling air.

Make sure that the mounting plate is not exposed to external temperature influences.

The mounting place shall be at least 30 cm from the magnetic aircraft compass, to avoid any interference to the magnetic compass (there are no restrictions for RCU6201 mounting).

2.4.1. AR6201 and RCU6201 Installation (Back Panel Mounting)

Leave a clearance of minimum 5 mm between the AR6201 respectively RCU6201 and other avionics to allow air circulation. Forced cooling is usually not required. For installation via rear side of the panel, four screws already attach to the front of the unit. The circular cut out and the mounting holes have to be prepared in accordance with Figure 2-3. For unit dimensions refer to Figure 2-5, Figure 2-4 and Figure 2-2.



61x61 mm (2.4x2.4 in)

Figure 2-2: AR6201 and RCU6201 front view

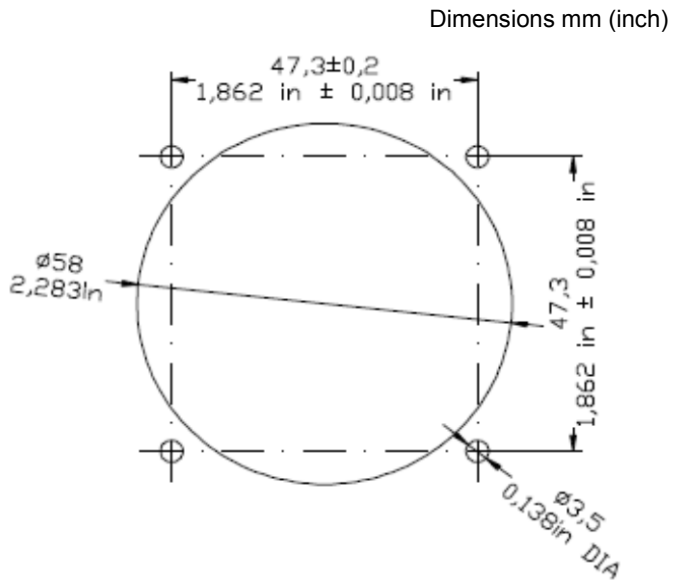

Figure 2-3: Drilling template (back-panel mounting)

Dimensions mm (inch)

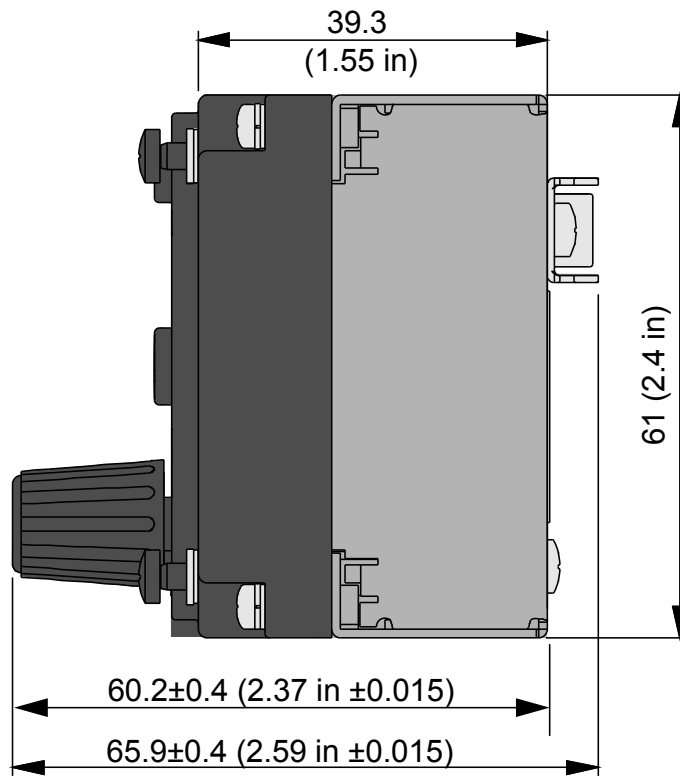
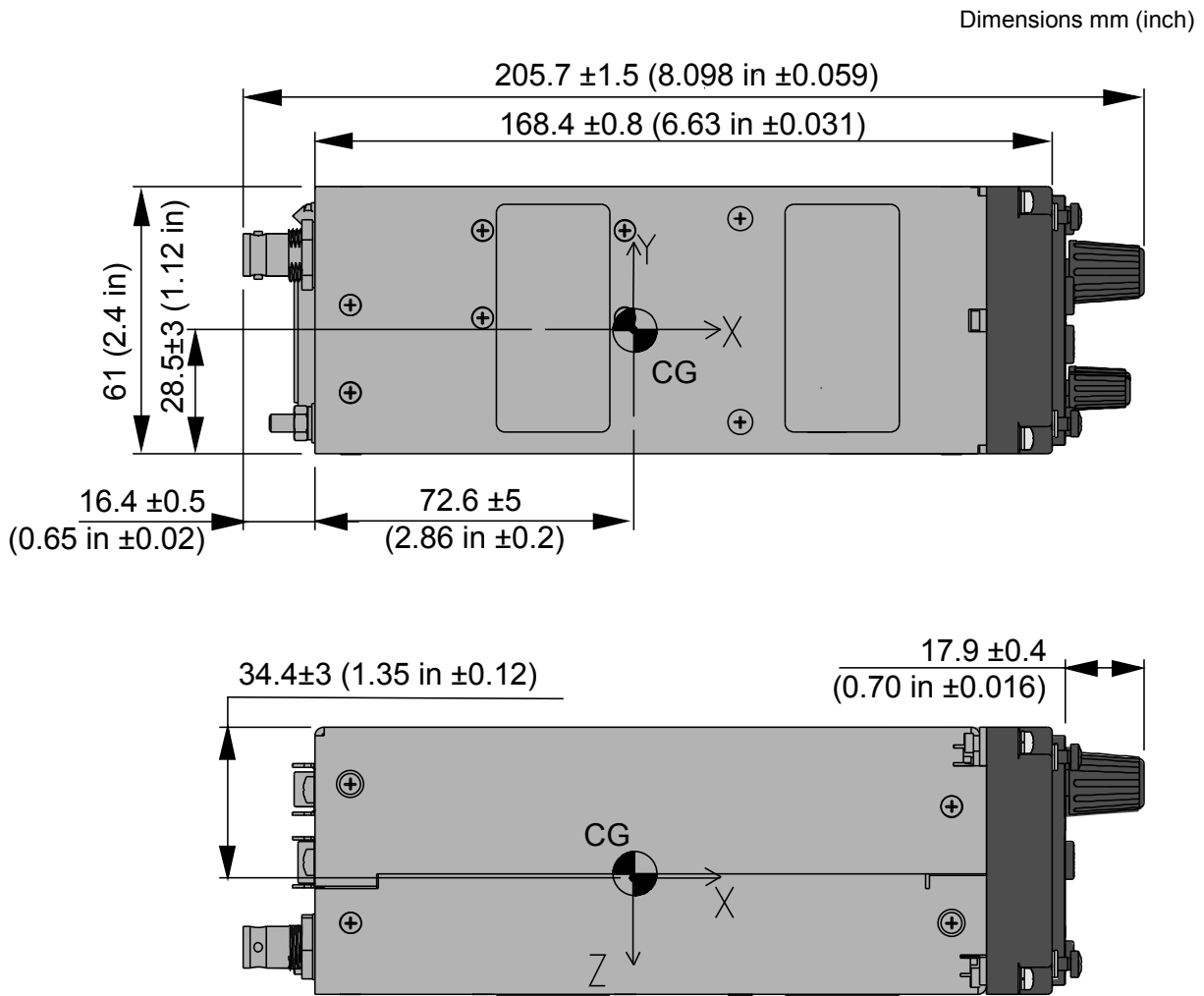

Figure 2-4: RCU6201 side view



 CENTER OF GRAVITY

Figure 2-5: AR6201 top view, side view

2.4.2. AR6203 Installation

Install AR6203 in the aircraft instrument panel within easy view and reach of pilot/operator. The location for AR6203 installation shall be at least 30 cm away from the aircraft magnetic compass, to avoid any interference to the magnetic compass caused by the transceiver. Leave a clearance of minimum 5 mm between the AR6203 and other avionics to allow air circulation. Forced cooling is usually not required.

For installation of the AR6203 use the designated mounting kit MK6403-1.

- Secure the mounting tray in the aircraft by using the 6 holes located on both sides of the frame, marked in the Figure with letter "C". Countersunk screws are included in the MK6403-1 kit.
- Slide AR6203 into the mounting tray all the way in, thereafter use an Allen wrench (3/32") to tightening the unit to its final position.

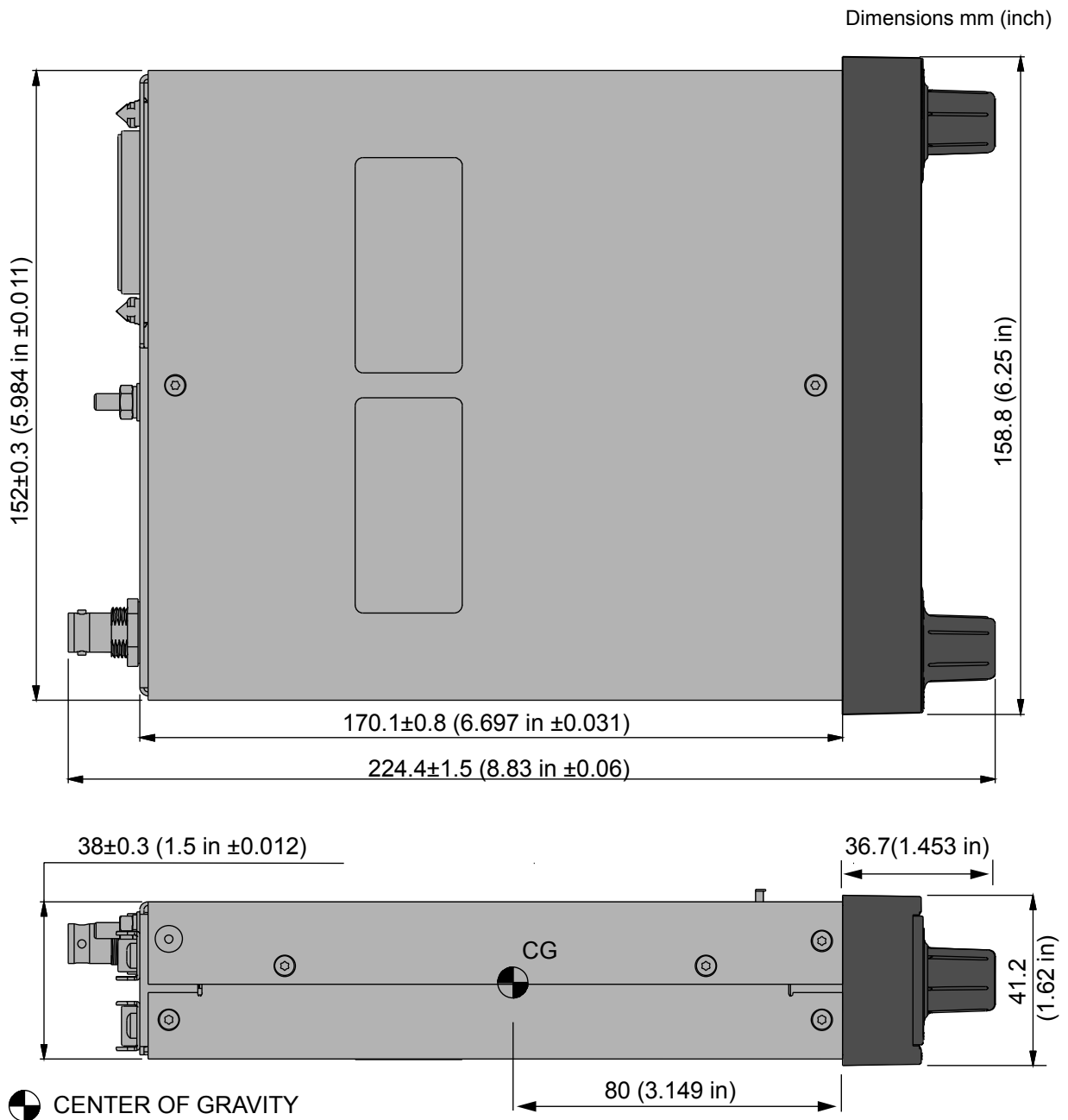

Figure 2-6: AR6203 top view, side view

Dimensions mm (inch)

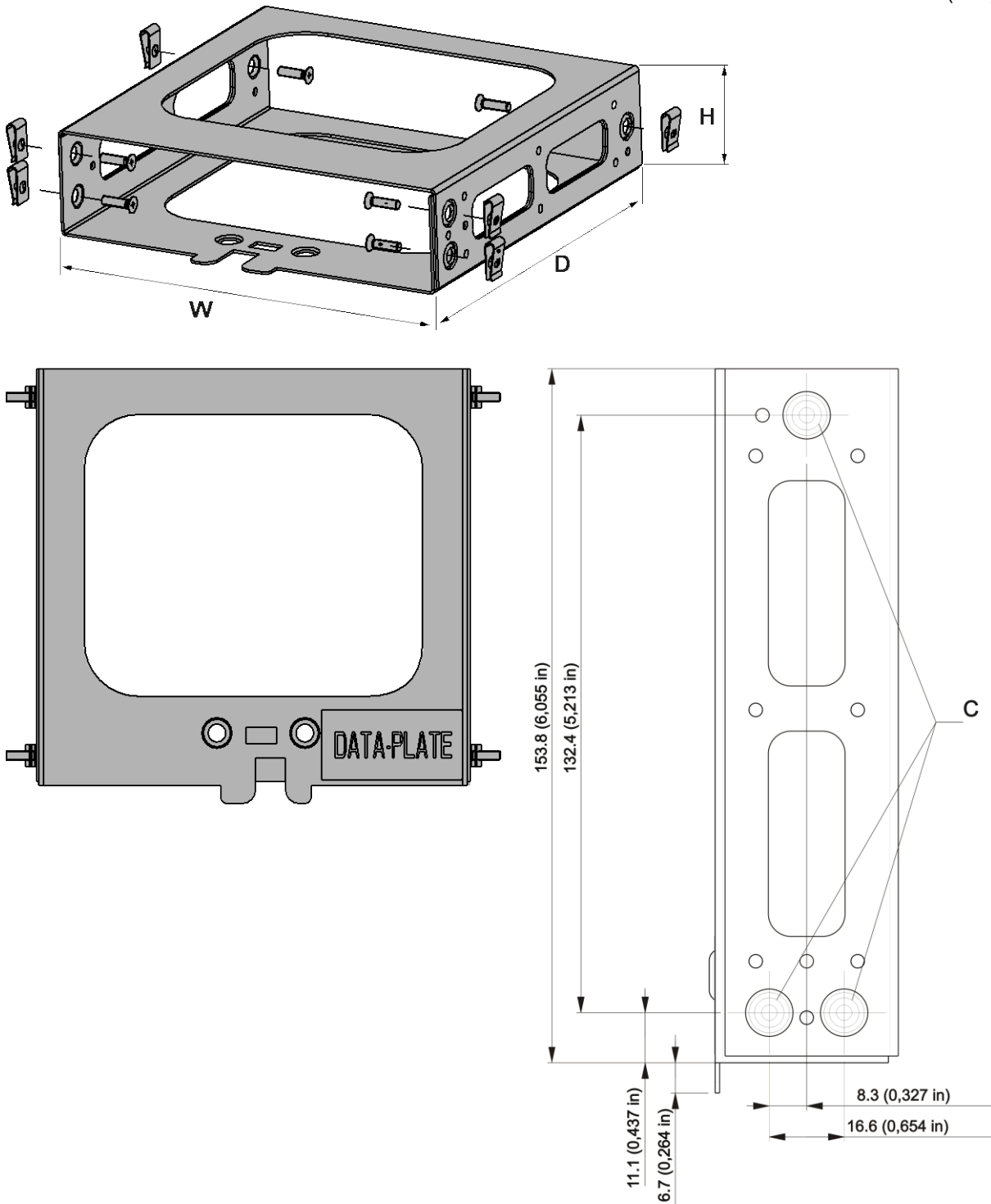

Figure 2-7: Mounting kit MK6403-1 (for AR6203)

Dimensions MK6403	
H	40.6 mm (1.598 in)
W	160.3 mm (6.311 in)
D	153.8 mm (6.055 in)

2.4.3. RT6201 Installation

Install the RT6201 at a suitable place in the aircraft for example directly on avionic bay or by using mounting kit MK6201-(010).

NOTICE

To meet the conditions for certification use the mounting method with mounting kit.

The mounting location for RT6201 shall be at least 30 cm away from the aircraft magnetic compass, to avoid any interference to the magnetic compass by the transceiver. Leave a clearance of minimum 5 mm between the RT6201 and other avionics to allow air circulation. Forced cooling is usually not required.

RT6201: Installation using RT6201 Mounting Holes

The required dimensions for installation using the mounting holes on the RT6201 are given in Figure 2-11 (dedicated holes are marked with "X" letter).

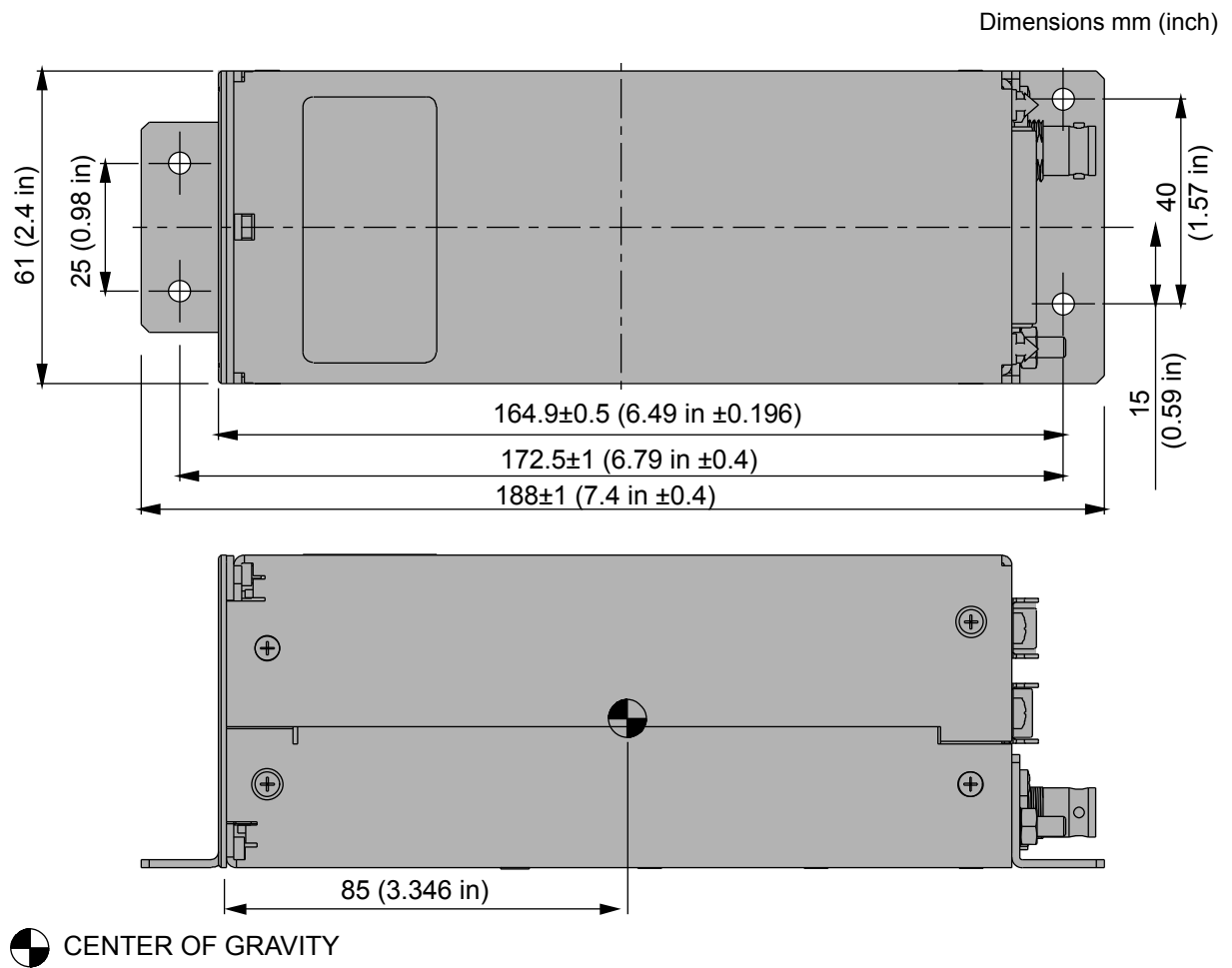

Figure 2-8: RT6201 top view, side view

Dimensions mm (inch)



Figure 2-9: RT6201 front view

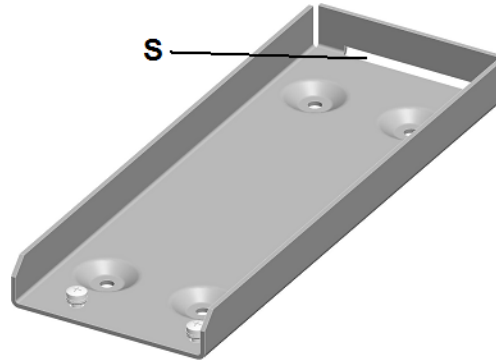

Figure 2-10: MK6201-(010) mounting kit

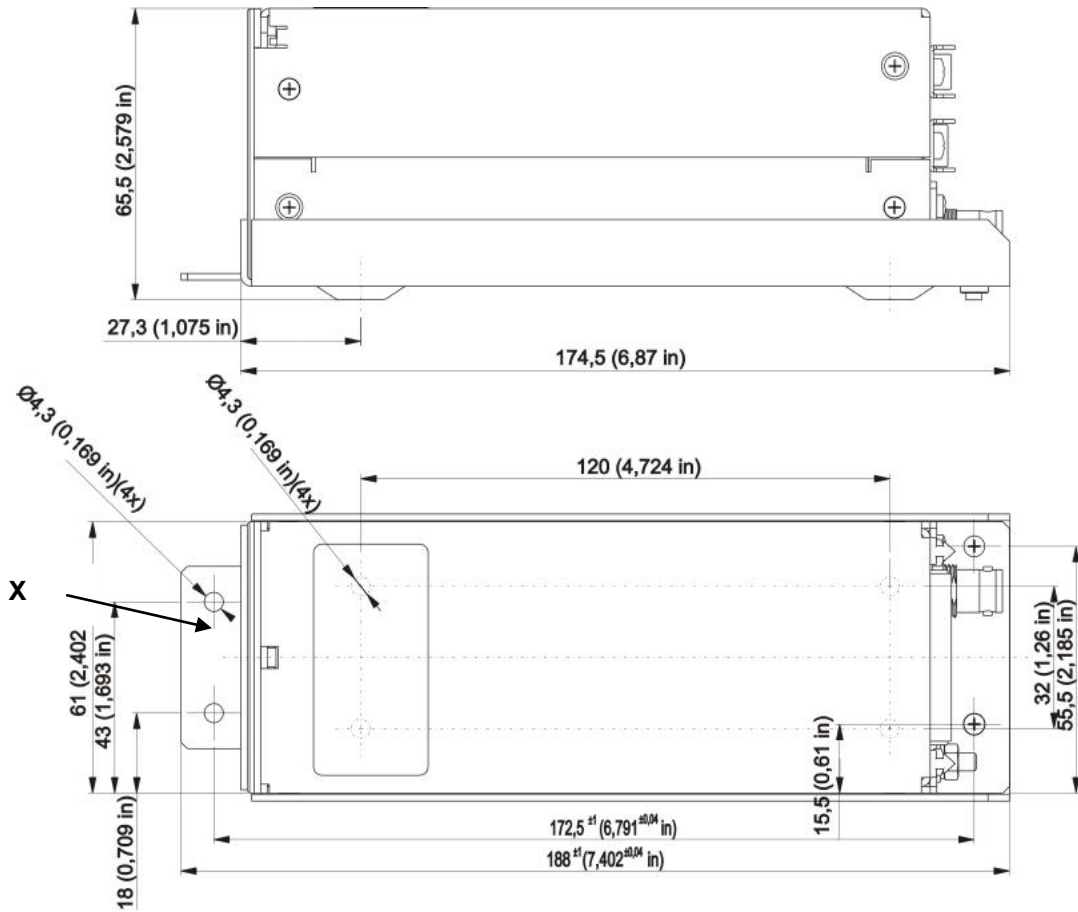

Figure 2-11: RT6201 with mounting kit MK6201

RT6201: Installation using Mounting Kit

The necessary dimensions for installation using the mounting kit MK6201-(010) are given in Figure 2-12 (dedicated holes marked with "B" letter).

Dimensions mm (inch)

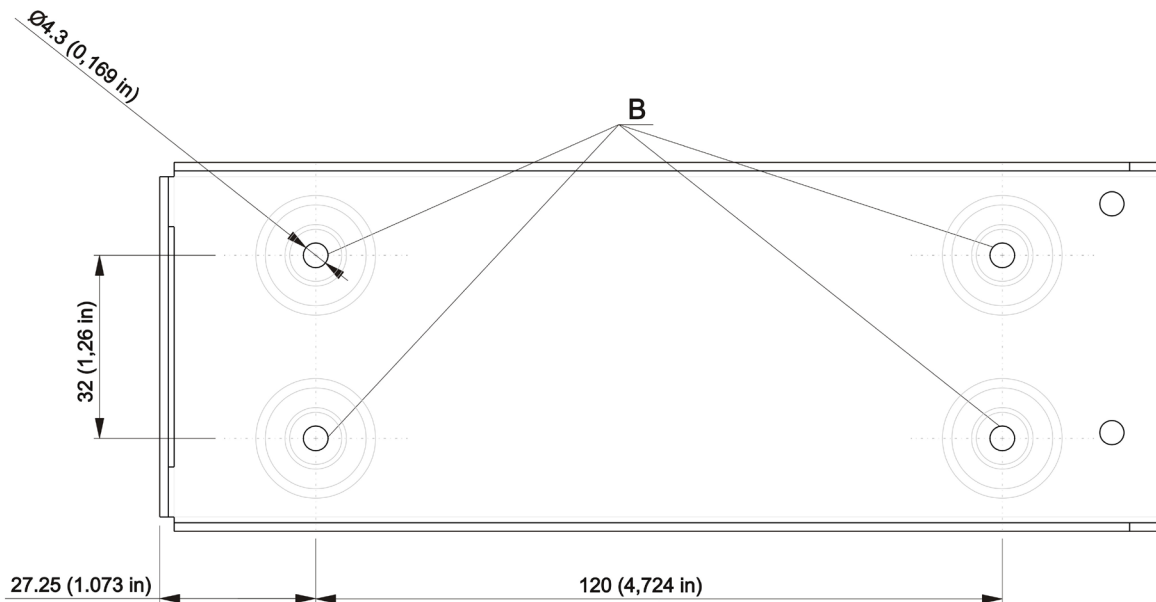

Figure 2-12: MK6201-(010) mounting slot fixing holes

First, secure the mounting kit frame in the aircraft, and then slide flat part "X" Figure 2-11 of the RT6201 into the mounting slot **S** (Figure 2-10). Use two M3 screws to tighten the unit to the mounting slot (details "A" shown on Figure 2-13). Suitable means are for example M3x6 DIN7985, associated flat washer 3.2 DIN433 and spring washer 3.1 DIN127B.

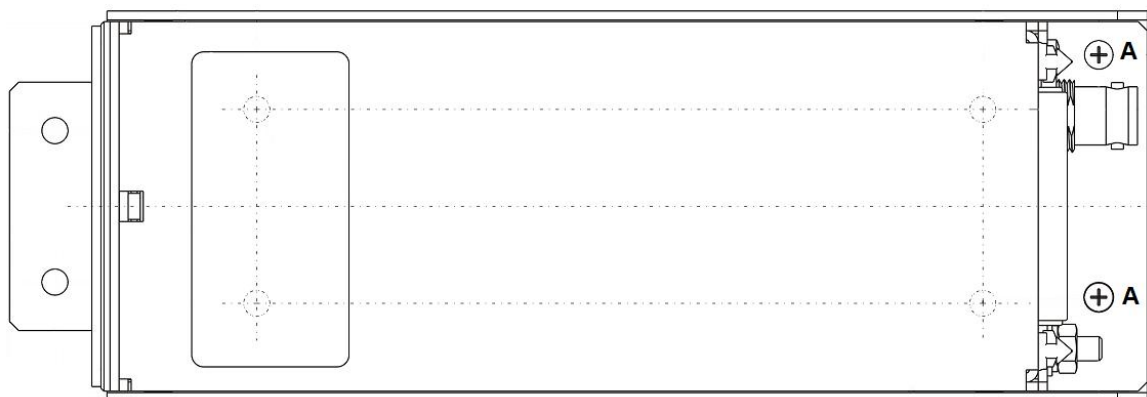

Figure 2-13: RT6201 top view, fixed on mounting slot

2.5. Electrical Interface

2.5.1. Connector and Pin Assignment (AR620X and RT6201)

Antenna Connector (Position 1)

The antenna connector (Figure 2-14, position 1) is a BNC type. The antenna port designed for operating with a nominal impedance of 50 Ω.

Grounding Bolt (Position 2)

The transceiver has a M4 threaded grounding bolt (Figure 2-14, position 2) allowing a low impedance grounding of the unit, which is essential to avoid damage or malfunction in the case of indirect lightning, EMI and HIRF conditions.

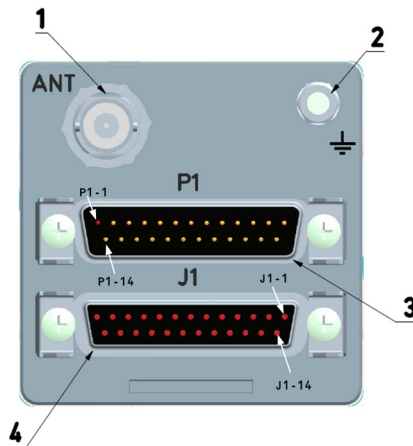

Figure 2-14: Rear plate AR6201 and RT6201, connectors P1 (male) and J1 (female)

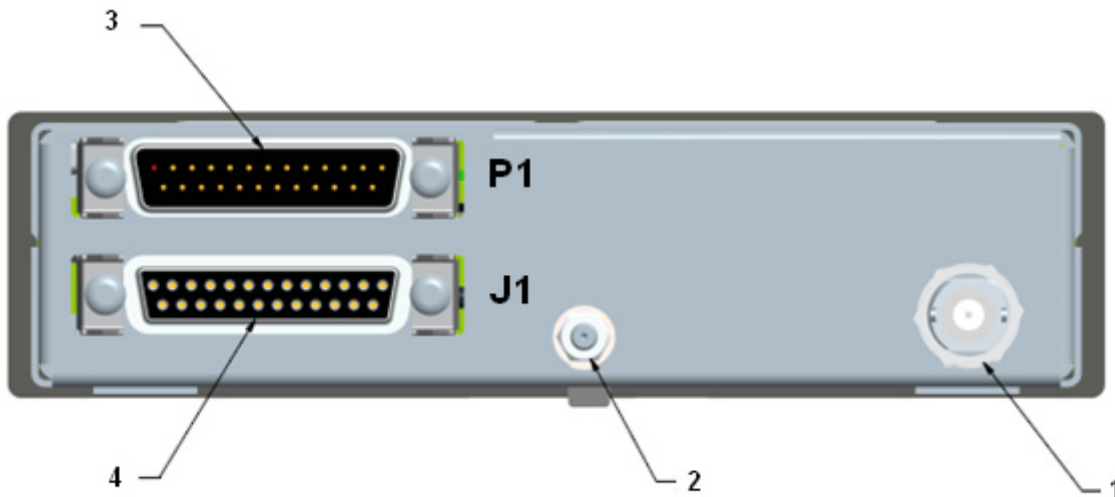

Figure 2-15: Rear plate AR6203, connectors P1 (male) and J1 (female)

P1 Connector (System Interfaces)

The P1 connector (Figure 2-14 and Figure 2-15, Position 3) is a DSUB male connector with 25 pins and slide-in fastener.

Pin No.	Pin Name	Direction	Function
P1-1	SPK_HI	OUT	Speaker output signal (hot)
P1-2	HDPH1_A	OUT	Balanced output for headphone(s)1
P1-3	HDPH1_B	OUT	Balanced output for headphone(s)1
P1-4	AF_AUX_IN_HI	IN	Auxiliary audio input (hot)
P1-5	MIKE_DYN_HI	IN	Balanced input for dynamic microphone(s)
P1-6	MIKE_DYN_LO	IN	Balanced input for dynamic microphone(s)
P1-7	/IC	IN	Intercom key input; ACTIVE state - closed contact to GND
P1-8	MIKE_STD_LO	-	Standard microphone(s) low (ground/return) used for STD1, STD2 and STD3
P1-9	MIKE_STD2_HI	IN	Standard microphone 2 High (hot)
P1-10	ILL_LO	IN	Illumination low input
P1-11	P_SUPP	IN	Power supply Hot (positive)
P1-12	P_SUPP	IN	Power supply Hot (positive)
P1-13	P_SUPP_GND	-	Power supply ground (return)
P1-14	SPK_LO	-	Speaker ground (return)
P1-15	LINE_OUT	OUT	Linear audio output, unbalanced
P1-16	AGC_OUT	OUT	Receiver AGC output
P1-17	/PTT1	IN	Press To Talk key input1 ACTIVE state - closed contact to GND
P1-18	MIKE_STD1_HI	IN	Standard Microphone 1 High (hot)
P1-19	MIKE_STD3_HI	IN	Standard Microphone 3 High (hot)
P1-20	HDPH2_A	OUT	Balanced Output for headphone(s)2
P1-21	AF_AUX_IN_LO	IN	Auxiliary audio input low (return)
P1-22	HDPH2_B	OUT	Balanced output for headphone(s)2
P1-23	ILL_HI	IN	Illumination high
	/PWR_EVAL	OUT	Power on monitor output
P1-25	P_SUPP_GND	-	Power supply ground (return)

J1 Connector (Serial Interfaces and Discrete I/O's)

The J1 connector is a D_SUB female connector with 25 sockets and slide-in fastener.

Pin No.	Pin Name	Direction	Function
J1-1	CPIN	-	Reserved coding pin
J1-2	TX2+	OUT	Auxiliary control interface
J1-3	RX2+	IN	Auxiliary Control Interface
J1-4	/SQL_EVAL	OUT	Squelch monitor output ACTIVE state - closed contact to GND
J1-5	/PTT2	IN	Press-To-Talk key input 2 ACTIVE state - closed contact to GND
J1-6	SHIELD_1	-	Secondary control & service interface SHIELD
J1-7	TX1+	OUT	Secondary control & service interface
J1-8	RX1+	IN	Secondary control & service interface
J1-9	TX2-	OUT	Auxiliary control interface
J1-10	RX2-	IN	Auxiliary control interface
J1-11	SHIELD_2	-	Auxiliary control interface SHIELD
J1-12	/EXT_SO	IN	External "Exchange" key Falling edge will activate frequency exchange
J1-13	/SRV_EN	IN	Service enable pin ACTIVE state - closed contact to GND
J1-14	TX1-	OUT	Secondary control & service interface
J1-15	RX1-	IN	Secondary control & service interface
J1-16	NC		not connected
J1-17	/SQL_SW	IN	"Squelch Force-OFF" input ACTIVE state - closed contact to GND
J1-18	NC		not connected
J1-19	NC		not connected
J1-20	/ISOL	IN	"ISOL" input ACTIVE state - closed contact to GND
J1-21	D_GND	-	Discrete lines ground
J1-22	D_GND	-	Discrete lines ground
J1-23	D_GND	-	Discrete lines ground
J1-24	/MIKE_SW	IN	Configuration selector CFG1 and CFG2
J1-25	/EXT_ON	IN	External Power ON input ACTIVE state - closed contact to GND

2.5.1.1. Inputs / Outputs

Microphone Connection – Standard Microphones

Pin No.	Pin Name	Direction	Function
P1-8	MIKE_STD_LO	-	Standard microphone(s) low (ground/return) used for STD1, STD2 and STD3
P1-9	MIKE_STD2_HI	IN	Standard microphone 2 high (hot)
P1-18	MIKE_STD1_HI	IN	Standard microphone 1 high (hot)
P1-19	MIKE_STD3_HI	IN	Standard microphone 3 high (hot)

The transceiver has three unbalanced inputs STD1, STD2 and STD3. Each input has an input impedance of 110 Ω and a nominal sensitivity of 110 mV.

This sensitivity level is adjustable in the installation setup from 9...1500 mV independently for each of the microphones. The power supply delivered from pins P1-9, P1-18 and P1-19 for supply of the connected microphone(s) is > 8 V DC (8.3 V nominal) open circuit with an output impedance of 120 Ω .

Note:

- Sensitivity range 25...1000 mV was qualified under environmental conditions.
- The AR/RT620X transceiver family provides power supply to support two microphones in parallel on each of the three standard microphone inputs. Combining only microphones of the same type / impedance is always highly recommended.
- In installations where high interferences were detected, we recommend the use of sensitivity levels between 27...1500 mV.
- We also recommend mounting the jacks generally isolated from aircraft frame in order to avoid ground loops.

Microphone Connection - Dynamic Microphone

Pin No.	Pin Name	Direction	Function
P1-5	MIKE_DYN_HI	IN	Balanced input for dynamic microphone(s)
P1-6	MIKE_DYN_LO	IN	Balanced input for dynamic microphone(s)

Interfacing with dynamic microphones, the transceiver provides balanced inputs with an impedance of 140 Ω and a nominal sensitivity of 1.6 mV. This sensitivity level is adjustable in the installation setup from 1...20 mV. Two dynamic microphones in parallel may be connected (identical technical characteristics of the microphones are preferable).

Note:

- The sensitivity range of 1...20 mV was qualified under environmental conditions. In installations where high interferences are detected we recommend the use of sensitivity levels between 2...20 mV.
- We also recommend mounting the jacks generally isolated from aircraft frame in order to avoid ground loops.

Speaker Connection

Pin No.	Pin Name	Direction	Function
P1-1	SPK_HI	OUT	Speaker output signal
P1-14	SPK_LO	-	Speaker ground (return)

The speaker output provides nominal 4 W into 4 Ω .

SAFETY INSTRUCTIONS

The magnetic field of a speaker influences the magnetic compass. When choosing the mounting point, a safe distance between the compass and the speaker must be determined. After speaker installation, verify the accuracy of the magnetic compass.

Headphone(s) Connection

Pin No.	Pin Name	Direction	Function
P1-2	HDPH1_A	OUT	Balanced output for headphone(s) 1
P1-3	HDPH1_B	OUT	Balanced output for headphone(s) 1
P1-20	HDPH2_A	OUT	Balanced output for headphone(s) 2
P1-22	HDPH2_B	OUT	Balanced output for headphone(s) 2

The headphone 1 output is a balanced, transformer-coupled output providing nominal 300 mW into 75 Ω. Using a shielded single wire for headphones requires an unbalanced output configuration. To achieve this, ground P1-3 (connect pin P1-13 with P1-25).

The headphone 2 output is a balanced output providing nominal 200 mW into 75 Ω.

Up to two headphones with phone-impedance of 300 Ω (or higher) may be connected in parallel on each circuit, therefore up to four headphones can be connected at the same time.

Note: It is highly recommended to mount the jacks isolated from aircraft frame in order to avoid ground loops.

CAUTION: The headphone 2 output shall be always floating (cannot be connected in unbalance configuration as headphone 1).

Panel Illumination

Pin No.	Pin Name	Direction	Function
P1-10	ILL_LO	IN	Illumination low input
P1-23	ILL_HI	IN	Illumination high input

The VHF transceiver provides illumination for pushbuttons and LCD display. Configuration of panel illumination provides the installation setup accessible via front panel. Depending on setup selection, 14 or 28 V fixed illumination voltage, or aircraft dim-bus voltage is in operation.

Connect ILL_LO (pin P1-10) to aircraft ground. Connect ILL_HI (pin P1-23) to dimming bus.

"Auxiliary" Audio Input

Pin No.	Pin Name	Direction	Function
P1-4	AF_AUX_IN_HI	IN	Auxiliary audio input hot
P1-21	AF_AUX_IN_LO	-	Auxiliary audio input low return

The AF auxiliary input enables to connect an external audio source (NAV, music-player, etc.) to the transceiver. The external audio is audible only when transceiver is in receiving mode.

Input sensitivity is adjustable in the installation setup from 50 mV...8 V. The impedance of this input is 600 Ω.

"LINE_OUT" Audio Output

Pin No.	Pin Name	Direction	Function
P1-14	SPK_LO	-	Speaker ground (return)
P1-15	LINE_OUT_HI	OUT	Linear audio output, unbalanced

The LINE OUT enables to connect e.g. an external voice recorder to the transceiver when used in ground-based installations. The LINE OUT output provides nominal 1 V_{RMS} into 1000 Ω.

External Power ON

Pin No.	Pin Name	Direction	Function
J1-25	/EXT_ON	IN	External Power ON input ACTIVE state - closed contact to GND

External Power ON input provides possibility to power "ON" the system by connecting this pin to ground.

Push-To-Talk (/PTT)

Pin No.	Pin Name	Direction	Function
P1-17	/PTT1	IN	Push-To-Talk key input 1 ACTIVE state - closed contact to GND
J1-5	/PTT2	IN	Push-To-Talk key input 2 ACTIVE state - closed contact to GND

There are two Push-to-Talk inputs available /PTT1 and /PTT2, e.g. one for the pilot and the other for the co-pilot.

Each input has an internal pull up. While the input is connected to ground a current of less than 1 mA will flow. The transceiver enters transmit operation, if either one or both inputs are connected to ground.

According to microphone(s) configuration, signal from particular inputs can or cannot modulate transmissions.

External Intercom Key (IC)

Pin No.	Pin Name	Direction	Function
P1-7	IC	IN	Intercom key input; ACTIVE state - closed contact to GND

With pin 7 connected to ground the transceiver provides intercom operation. This input has an internal pull up and is LO active. For installations where automatic intercom operation activates via VOX, a connection of pin 7 is not necessary. While connected to ground, a current of max. 1 mA will flow.

This discrete input activates the intercom:

- When VOX does not work satisfactorily because of extreme loud cockpit environment caused e.g. by ambient noise.
- When speaker is enabled in current audio in/out configuration (installation setup)

Isolation Mode (/ISOL)

Pin No.	Pin Name	Direction	Function
J1-20	/ISOL	IN	ISOL input for separation from co-pilot (passenger) ACTIVE state - closed contact to GND

AR620X transceiver provides two microphone paths. Each microphone path allows connection of two individual microphones. Depending on configuration, it is possible to connect pilot and co-pilot microphones on one path and two passenger microphones on the second.

When /ISOL is active (isolation mode) passengers are isolated from pilots intercom as well as from the radio transmission, but still can freely communicate with each other.

When /ISOL is inactive both the pilots and the passengers connected to one common intercom circuit.

Power Indication (/PWR_EVAL)

Pin No.	Pin Name	Direction	Function
P1-24	/PWR_EVAL	OUT	Power on Monitor output: AR6201 "OFF" - open circuit AR6201 on - closed circuit to GND (max. 100 mA)

This output indicates whether the transceiver is in "ON" or "OFF" status by means of an open collector function. The output internally connects to ground when the unit is "ON" and allow a current of maximum 100 mA to drive an external relay for example. The output shows high impedance when the transceiver is "OFF".

Note: In order to avoid damage of this output a protection diode in parallel to the external relay shall connected.

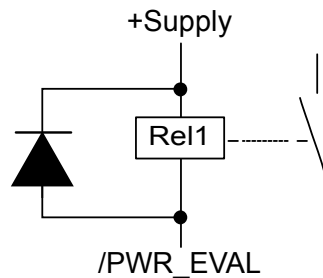

VHF Channel Signal Indication (/SQL_EVAL)

Pin No.	Pin Name	Direction	Function
J1-4	/SQL_EVAL	OUT	Indicates presence of the VHF channel's signal on the audio outputs.

This output indicates presence of the VHF channel's signal on the audio outputs. It is an open collector output type. The output internally connects to ground when the unit receives signal on the selected VHF channel and this audio signal is available on audio outputs. In this case a current of maximum 100 mA can flow into the transceiver to drive an external relay for example. The output has high impedance if the unit is switched off.

External Mike Switch (/MIKE_SW)

Pin No.	Pin Name	Direction	Function
J1-24	/MIKE_SW	IN	Configuration selector CFG1 and CFG2. ACTIVE state - closed contact to GND

The external Mike switch provides selection between the two available audio in/out configurations: CFG1 and CFG2. Configurations can also be changed during flight in installation setup.

- When /MIKE_SW is active then configuration CFG1 is in use.
- When /MIKE_SW is inactive then CFG2 is in use.

Each configuration CFG1 and CFG2 stores several parameters that can be set in installation setup pages. (For details, refer to chapter 2.8).

2.5.2. Connector and Pin Assignment (RCU6201)

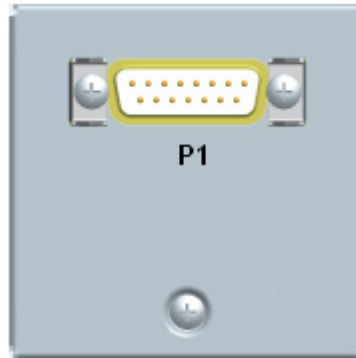

Figure 2-16: Connector on rear plate of RCU6201

P1 Connector (System Interface)

The P1 connector (Figure 2-16) is a DSUB male connector with 15 pins and slide-in fastener.

Pin No.	Pin Name	Direction	Function
P1-1	TX0_422+	OUT	Primary Control & Service Interface
P1-2	TX0_422-	OUT	Primary Control & Service Interface
P1-3	RX1_422+	IN	Auxiliary Control Interface
P1-4	RX0_422+	IN	Primary Control & Service Interface
P1-5	RX0_422-	IN	Primary Control & Service Interface
P1-6	ILL_LO	IN	Illumination low input
P1-7	TX1_422-	OUT	Auxiliary Control Interface
P1-8	ILL_HI	IN	Illumination high
P1-9	GND	-	Power supply Ground (return), shielding for RS422, Ground for discrete lines
P1-10	RX1_422-	IN	Auxiliary Control Interface
P1-11	SUPP_IN	-	Power supply Hot (positive)
P1-12	/SRV_EN	OUT	Service enable pin ACTIVE state - closed contact to GND
P1-13	/EXT_ON	IN	External Power ON input ACTIVE state - closed contact to GND
P1-14	TX1_422+	OUT	Auxiliary Control Interface
P1-15	/EXCH_CH	IN	External "Exchange" key ACTIVE state - closed contact to GND

Panel Illumination

Pin No.	Pin Name	Direction	Function
P1-6	ILL_LO	IN	Illumination low input
P1-8	ILL_HI	IN	Illumination high input

The RCU6201 controller push-buttons and LCD display can be illuminated. The illumination can be configured in the installation setup via front panel or externally via pin P1-6/P1-8. For external configuration connect pin P1-6 to system ground and pin P1-8 to dimming voltage bus.

External Power ON (/EXT_ON)

Pin No.	Pin Name	Direction	Function
P1-13	/EXT_ON	IN/OUT	External Power ON input/output ACTIVE state - closed contact to GND

The External Power "ON" input provides the possibility to power on the system by ensuring this pin is earthed. This can be connected in installations with a central avionics power switch or to power on RT6201.

External Exchange (/EXCH_CH)

Pin No.	Pin Name	Direction	Function
P1-15	/EXCH_CH	IN	External "Exchange" key ACTIVE state - closed contact to GND

The External "Exchange" input provides possibility to change active and preset frequency or activate SCAN mode by means of momentary switch.

2.6. Installation and Configuration

Connection to the following equipment is required as minimum for 620X transceivers:

- Power supply
- Antenna
- Microphone (direct or via external audio panel)
- Headphone or speaker (direct or via external audio panel)
- Push-To-Talk (PTT) switch

SAFETY INSTRUCTIONS

Use only cables which are qualified for aircraft use (self-extinguishing).

Use AWG 20 for power supply and AWG 22/24 for other cables.

Fit sleeves over the solder joints on the equipment connector. Crimp connectors are also available from Becker.

Protect the power supply with a 7.5 A fuse.

The VHF transceiver is protected internally by a 5 A fuse.

- Type-specific cable harnesses are also available for the aircraft wiring (contact BECKER for detailed information).
- No RF antenna cables or HF cables should be included in the cable harnesses of the system. Avoid routing of the cable loom along with other wiring, which carry audio power or pulses.
- Check the wiring carefully before powering up the unit and check particularly that power supply lines are not interchanging.

Installation of 620X transceivers requires correct wiring and configuration. All necessary information for common installations shows article **Fehler! Verweisquelle konnte nicht gefunden werden.**, including wiring diagrams and recommended installation setup configurations.

Aircraft Type	Chapter Reference
<div style="background-color: green; color: white; padding: 2px; display: inline-block;">SAFETY INSTRUCTIONS</div> Installation of the unit varies according to aircraft and equipment design. It is therefore only possible to provide general guidelines in this section.	0, page 70
Single Seat Glider	
Twin Seat Motor Glider	2.10.2, page 73
General Aviation (GA) Aircraft	2.10.3, page 75
Individual Dual Headset Configuration (two IC Circuit)	2.10.4, page 77
Twin Seat with AR620X Tandem Configuration	2.10.5, page 79
Aircraft with four Seats (no TANDEM)	2.10.6, page 81
Installation with RT6201 and RCU6201	2.10.7, page 83
Aircraft with Intercom System	2.10.8, page 84
Twin Seat with RT6201 Tandem Configuration	2.10.9, page 87

2.7. Antenna Installation

The transceiver requires a standard 50 Ω vertically polarized VHF antenna. Follow manufacturer's instructions for antenna installation. In addition, consider the following recommendations:

- The COM antenna shall be on an electrical conductive surface or, on a ground plane with sufficient area of approximately 60 x 60 cm installed. (VSWR ≤ 3:1)
- Separate the COM antenna from any installed GPS antennas by at least 50 cm and as far away from any ELT antenna.

Note: Some ELTs have exhibited re-radiation problems generating harmonics that may cause interference with other receivers like GPS. This can happen when the transceiver or other COMM devices are transmitting on certain frequencies such as 121.5 MHz or 121.175 MHz, which may cause the ELT output circuit to auto-oscillate.

2.8. Installation Setup

The installation setup enables the avionics technician to set up the equipment configuration on ground.

We do not recommend performing changes on the installation setup in-flight.

In most cases, entering installation setup will be from the primary controller to access controller and transceiver parameters. If installed, the second controller (RCU6201) should be switched off. Installation setup on RCU6201 gives access to parameters of second controller. RCU6201 installation setup shall be used only if different settings for "BRIGHTENSS" or "ILLUMINATION CURVE" are required.

- Note:
- For single block AR620X, primary controller is this one directly connected to transceiver, for remote RT6201 transceiver primary controller is this one connected to primary control interface.
 - After power on the second controller (RCU6201) parameters are synchronized with those stored in primary controller. Any stored parameters in second controller (RCU6201) will be overwritten!

2.8.1. Start Installation Setup

Hold down the "MDE" key during power up to access the installation setup menu. The "PASSWORD DIALOG" screen will appear.

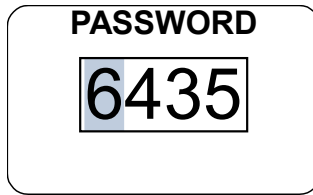

Figure 2-17: "PASSWORD DIALOG"

Insert the 4-digit numerical code password "6435" by turning and pushing the "ROTARY ENCODER". Confirm by pressing the "STO" key. Now the first page of installation setup shows the "DEVICE INFO" screen.

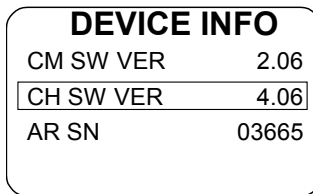

Figure 2-18: "DECIVE INFO"

2.8.2. Navigate between Pages

The installation setup consists of several pages. Navigation within main pages:

Page Down (next page): press "↓/SCN" or the "ROTARY ENCODER".

Page Up (previous page): press "IC/SQL" key.

For navigation within the sub-pages of the installation setup, use the "ROTARY ENCODER".

2.8.3. Store Setup Data

The setting of any parameter is stored immediately after changing the parameter.

2.8.4. Leave Installation Setup

Switch "OFF" the AR620X or RCU6201 to terminate the setup. All changes made up to this time will be stored automatically. No special action is required before leaving setup page.

2.8.5. Adjust Volume Settings (VU Meter)

The VU Meter allows correct adjustment of audio input sensitivity. It is displayed on all sensitivity setting menus.

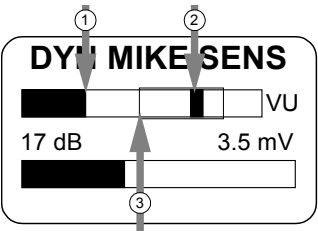

Display Contents	Description
<p>Example:</p>  <p>1: Current audio level 2: Hold max. level 3: Recommended range (inside frame)</p>	<p>VU Meter, it is located in the middle below the menu name and above the dedicated sensitivity setting bar.</p> <p>It displays the current audio level value on selected audio input ("Current audio level") and holds the highest value of active audio level recorded during last 3 seconds (displayed as "Hold max level" bar).</p> <p>Correct sensitivity is achieved if most of the time, while you are speaking normally into the microphone, the "Hold max level" bar remains in the "Recommended range".</p>

2.8.6. Installation Setup Pages - Description

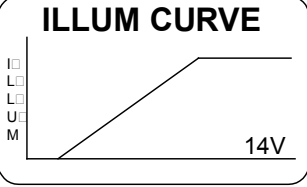
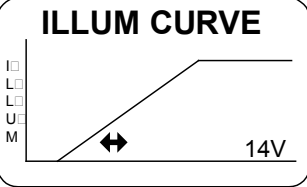
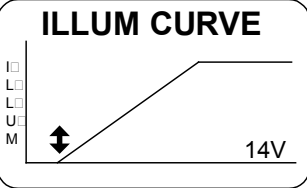
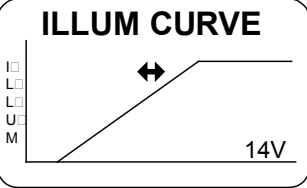
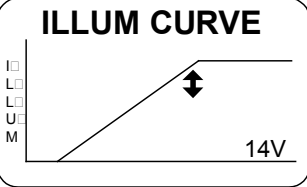
Display Contents	Description																		
<p style="text-align: center;">AR620X</p> <div style="border: 1px solid black; padding: 5px; margin: 10px 0;"> <p style="text-align: center;">DEVICE INFO</p> <table style="width: 100%; border-collapse: collapse;"> <tr> <td style="width: 70%;">CM SW VER</td> <td style="text-align: right;">2.06</td> </tr> <tr> <td style="border-bottom: 1px solid black;">CH SW VER</td> <td style="text-align: right; border-bottom: 1px solid black;">4.06</td> </tr> <tr> <td>AR SN</td> <td style="text-align: right;">03665</td> </tr> </table> </div> <p style="text-align: center;">RCU6201 as primary controller of RT6201</p> <div style="border: 1px solid black; padding: 5px; margin: 10px 0;"> <p style="text-align: center;">DEVICE INFO</p> <table style="width: 100%; border-collapse: collapse;"> <tr> <td style="width: 70%;">CM SW VER</td> <td style="text-align: right;">2.06</td> </tr> <tr> <td style="border-bottom: 1px solid black;">CH SW VER</td> <td style="text-align: right; border-bottom: 1px solid black;">4.06</td> </tr> <tr> <td>CM SN</td> <td style="text-align: right;">00005</td> </tr> <tr> <td>CH SN</td> <td style="text-align: right;">00005</td> </tr> </table> </div> <p style="text-align: center;">RCU6201 as secondary controller</p> <div style="border: 1px solid black; padding: 5px; margin: 10px 0;"> <p style="text-align: center;">DEVICE INFO</p> <table style="width: 100%; border-collapse: collapse;"> <tr> <td style="width: 70%;">CH SW VER</td> <td style="text-align: right;">4.06</td> </tr> <tr> <td>CH SN</td> <td style="text-align: right;">00005</td> </tr> </table> </div>	CM SW VER	2.06	CH SW VER	4.06	AR SN	03665	CM SW VER	2.06	CH SW VER	4.06	CM SN	00005	CH SN	00005	CH SW VER	4.06	CH SN	00005	<p>"DEVICE INFO":</p> <p>After entering the "Installation Setup" the first page "DEVICE INFO" is displayed. This page shows information about the SW version and the serial number of the transceiver.</p> <p>For AR620X "DEVICE INFO" displays information about;</p> <ul style="list-style-type: none"> • Transceiver SW version (CM SW VER). • Controller SW version (CH SW VER). • AR620X serial number (AR SN). <p>For RCU6201 connected as primary controller of an RT6201, this page displays information about;</p> <ul style="list-style-type: none"> • Transceiver SW version. • Controller SW versions (CH SW VER). • RT6201 serial number (CM SN). • RCU6201 serial number (CH SN). <p>For RCU6201 connected as secondary controller this page displays information about;</p> <ul style="list-style-type: none"> • Controller SW version (CH SW VER). • RCU6201 serial number (CH SN).
CM SW VER	2.06																		
CH SW VER	4.06																		
AR SN	03665																		
CM SW VER	2.06																		
CH SW VER	4.06																		
CM SN	00005																		
CH SN	00005																		
CH SW VER	4.06																		
CH SN	00005																		
<div style="border: 1px solid black; padding: 5px; margin: 10px 0;"> <p style="text-align: center;">DIMMING INPUT</p> <ul style="list-style-type: none"> • NONE ○ 0-14V ○ 0-28V </div>	<p>"DIMMING INPUT":</p> <p>One of three options can be selected by turning the "ROTARY ENCODER" to dim illumination for the display and push-button. Finalize the selection by pressing "STO" push-button.</p> <p>NONE:</p> <p>The illumination for LCD and push-buttons is controlled via the "ROTARY ENCODER" on the transceiver itself. The pilot can adjust the brightness in the pilots menu.</p> <p>0...14 V or 0...28 V:</p> <p>The background lighting for LCD and push-buttons is controlled (via pin P1-10/P1-23) by the dimming bus of the aircraft. The dimming curve is adjustable within the range from 0... 14 VDC respectively 0...2 VDC. Adjusting the brightness via the "ROTARY ENCODER" is no longer possible after selecting this option.</p> <p>Note: Menu available on primary and secondary controller.</p>																		

Display Contents	Description
<p>BRIGHTNESS</p> <p style="font-size: 24px; font-weight: bold;">65</p> 	<p>"BRIGHTNESS":</p> <p>The brightness of the LCD and push-button illumination can be adjusted between 0% (off) and 100%. Select your brightness by turning "ROTARY ENCODER". The BRIGHTNESS settings can also be adjusted in the pilot setup menu. Pilots can change the parameter at any time.</p> <p>BRIGHTNESS settings are separate for each controller therefore this menu is available on both controllers.</p> <p>Note: This page is displayed only if dimming input is set to "NONE". Otherwise the aircraft dimming bus will control the brightness</p>
<p>ILLUM CURVE</p> 	<p>"ILLUM CURVE":</p> <p>The page "ILLUM CURVE" is displayed only if the DIMMING input is either selected for "14 V or 28 V" dim-bus voltage. The illumination curve shows the relation between dimming bus voltage and brightness of the LCD and push-button illumination.</p> <p>Two adjustable points V1 and V2 define the illumination curve.</p> <p>Select the respective parameter by pushing the "STO" button and then adjust the value in horizontal (left/right) respectively vertical (up/down) direction using the "ROTARY ENCODER".</p> <p>Note: Menu available on primary and secondary controller.</p>
<p>ILLUM CURVE</p> 	<p>(1) This parameter defines the horizontal parameter V1x (minimum values: 1.5 V for 14 V dimming bus and 4 V for 28 V dimming bus). Up to this value the brightness is zero. When reaching V1x the brightness is immediately adjusted to V1y.</p>
<p>ILLUM CURVE</p> 	<p>(2) This parameter defines the vertical parameter V1y which is the level of brightness that is set when trigger point V1x is reached.</p>
<p>ILLUM CURVE</p> 	<p>(3) This parameter defines the horizontal parameter V2x (maximum values: 14 V or 28 V depending on selected dimming input) where the illumination curve reaches the maximum brightness level.</p>
<p>ILLUM CURVE</p> 	<p>(4) This parameter defines the vertical parameter V2y which is the maximum brightness.</p>

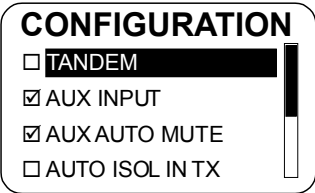
Display Contents	Description
<div style="border: 1px solid black; padding: 5px;"> <p>MEM OPTIONS</p> <p><input checked="" type="checkbox"/> CHANNEL STORE</p> <p><input checked="" type="checkbox"/> STORE LAST CHANNELS</p> </div>	<p>"MEM OPTIONS":</p> <p>Two options can be selected on "MEMORY OPTIONS" page. By means of the "ROTARY ENCODER" one option can be highlighted and enabled/ disabled by pushing the "STO" button.</p> <p>CHANNEL STORE:</p> <p>If this option is enabled frequencies can be stored in any of the 99 available channels.</p> <p>Even if the "CHANNEL STORE" option is disabled the user has access to previously stored "User Channels"</p> <p>STORE LAST CHANNEL</p> <p>If this option is enabled, the device automatically stores the last used VHF frequency in "Last Channel" database and user has a read access to this database.</p> <p>If this option is disabled the stored data in the "LAST CHANNEL" database is not accessible.</p> <p>Note: Menu available on primary and secondary controller.</p>
<div style="border: 1px solid black; padding: 5px;"> <p>MDE PAGES</p> <p><input checked="" type="checkbox"/> STANDBY FREQUENCY</p> <p><input checked="" type="checkbox"/> BATTERY VOLTAGE</p> <p><input checked="" type="checkbox"/> CHANNEL MEMORY</p> </div>	<p>"MDE PAGES":</p> <p>On "MDE PAGES" page three options are selectable by means of the "ROTARY ENCODER". The three frequency selection modes provide different user interfaces for operating frequency selection. Enabling/Disabling can be toggled by pushing the "STO" button.</p> <p>STANDBY FREQUENCY</p> <p>Enables/disables "Standard Mode"</p> <p>BATTERY VOLTAGE</p> <p>Enables/disables "Direct Tune Mode".</p> <p>CHANNEL MEMORY</p> <p>Enables/disables "Channel Mode".</p> <p>After deselecting "BATTERY VOLTAGE" the "DIRECT TUNE MODE" page is no longer available in the normal operation.</p> <p>Storing a frequency in a specific channel will be possible even if only "BATTERY VOLTAGE" or "STANDBY FREQUENCY" remain selected.</p> <p>At least one page will remain active, deselecting all options from the "MDE PAGES" is not possible</p> <p>Note: Menu available on primary and secondary controller.</p>
<div style="border: 1px solid black; padding: 5px;"> <p>LOW BATT THR</p> <p style="text-align: center;">10.5</p> <div style="border: 1px solid black; width: 100px; height: 15px; margin-top: 5px;"> <div style="background-color: black; width: 10%;"></div> </div> </div>	<p>"LOW BATT THR":</p> <p>On "LOW BATT THR" page the threshold for indication of the "LOW BATT" warning page can be adjusted (default setting is 10.5 V). The low battery threshold depends on battery type in use and should be adjusted within 10...33 V by the installer turning the "ROTARY ENCODER". "LOW BATT" warning page is displayed if the supply voltage drops below the "LOW BATT THR" value.</p> <p>Recommended vales:</p> <p>"LOW BATT THR" = 11 V for 12 V battery</p> <p>"LOW BATT THR" = 24 V for 24 V battery</p> <p>Note: Menu available on primary and secondary controller.</p>

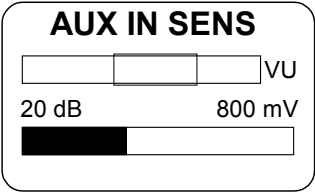
Display Contents	Description
 <p style="text-align: center;">Options 1...4</p>	<p>"CONFIGURATION": On "CONFIGURATION" page 6 or 7 options can be selected. (refer to the note under AUX AUTO MUTE in the column on the right side). Use the "ROTARY ENCODER" to scroll up and down, then and push the "STO" button for selection.</p> <p>TANDEM If selected, a second controller RCU6201 can be connected to AR620X/RT6201.</p> <p>AUX INPUT If selected, the auxiliary audio signal applied to pins P1-4 / pin P1-21 is audible on headphone / speaker. Note: If the auxiliary audio input is not used, it is recommended to deselect "AUX INPUT".</p> <p>AUX AUTO MUTE If selected the auxiliary audio input will be muted. The auxiliary audio input is also muted if the receiver detects (based on squelch evaluation) a signal. When deselected the auxiliary audio input signal and the receiver signal will intermix continuously. Note: "AUX AUTO MUTE" is only displayed when "AUX INPUT" is enabled.</p> <p>AUTO ISOL IN TX If selected a separation between the pilots and passenger intercom circuits is provided while one of the pilots transmits.</p> <p>SCAN BEEP If selected the transceiver generates (only in scan function) a short beep tone to notify a signal presence on the "PRESET FREQUENCY". During signal reception on the "ACTIVE FREQUENCY" switch over to the "PRESET FREQUENCY" is not possible. The audio remains on "ACTIVE FREQUENCY" and a short beep tone is audible. Additionally the "PRESET FREQUENCY" will appear contrast inverted in a sequence of approximately one second.</p> <p>FREQ CHANGE BEEP If selected the transceiver generates a short beep on each change of the "ACTIVE FREQUENCY".</p> <p>SWAP MIKE IC If selected the /IC input functions as /MIKE_SW input and /MIKE_SW input operates as /IC input.</p>
 <p style="text-align: center;">Options 4...7</p>	<p>"AUX IN SENS": On "AUX IN SENS" page the sensitivity adjustment of the auxiliary audio input (Pin P1-4 / Pin P1-21), in the range 50...8000 mV, can be set by turning the "ROTARY ENCODER". This page is displayed only if ENABLE_AUX_IN is activated. The VU meter shows the current signal level of the aux audio input and always displays the highest detected signal value from the last 3 seconds. Note: Menu available on primary controller.</p>
	

Display Contents	Description
<div style="border: 1px solid black; padding: 5px; text-align: center;"> <p>AUTO AUX ATT</p> <p>20</p>  </div>	<p>"AUTO AUX ATT":</p> <p>On "AUTO AUX ATT" page the attenuation for the auxiliary audio input can be adjusted between 0...40 dB by turning the "ROTARY ENCODER"</p> <p>When intercommunication is initiated (regardless of the intercom activation: "VOX", or "/IC" discrete input) the signal from auxiliary audio input will be attenuated. After intercommunication is finished the auxiliary audio will revert to its previous level.</p> <p>Note: Menu available on primary controller.</p>
<div style="border: 1px solid black; padding: 5px;"> <p>IN/OUT CFG 1</p> <div style="border: 1px solid black; padding: 2px; margin-bottom: 5px;"> <p>MICROPHONE 1</p> <ul style="list-style-type: none"> <input type="radio"/> STD 1 MIKE <input type="radio"/> STD 2 MIKE <input type="radio"/> STD 3 MIKE <input checked="" type="radio"/> DYN MIKE <input type="radio"/> NONE </div> <div style="border: 1px dashed black; padding: 2px;"> <p>MICROPHONE 2</p> <ul style="list-style-type: none"> <input type="radio"/> STD 1 MIKE <input type="radio"/> STD 2 MIKE <input type="radio"/> STD 3 MIKE <input type="radio"/> DYN MIKE <input checked="" type="radio"/> NONE <p>MIC ACTIVATION</p> <ul style="list-style-type: none"> <input checked="" type="checkbox"/> BOTH MIKES <p>OUTPUTS</p> <ul style="list-style-type: none"> <input checked="" type="checkbox"/> HEADPHONE 1 <input type="radio"/> HEADPHONE 1 <input type="radio"/> SPEAKER <input type="radio"/> NONE </div> </div>	<p>"IN/OUT CFG 1":</p> <p>On "IN/OUT CFG 1" page the microphone inputs and headphone outputs for configuration CFG1 can be configured. To scroll the page turn the "ROTARY ENCODER".</p> <p>"MICROPHONE 1" (at one time only one option can be selected):</p> <p>STD1 MIKE Standard microphone input 1 (Pins P1-18/ P1-8) is selected.</p> <p>STD2 MIKE Standard microphone input 2 (Pins P1-9/ P1-8) is selected.</p> <p>STD3 MIKE Standard microphone input 3 (Pins P1-19/ P1-8) is selected.</p> <p>DYN MIKE Dynamic microphone input (Pins P1-6/ P1-5) is selected.</p> <p>NONE No microphone is used in microphone path 1.</p> <p>"MICROPHONE 2" (at one time only one option can be selected):</p> <p>STD1 MIKE Standard microphone input 1 (Pins P1-18/ P1-8) is selected.</p> <p>STD2 MIKE Standard microphone input 2 (Pins P1-9/ P1-8) is selected.</p> <p>STD3 MIKE Standard microphone input 3 (Pins P1-19/ P1-8) is selected.</p> <p>DYN MIKE Dynamic microphone input (Pins P1-6/ P1-5) is selected.</p> <p>NONE No microphone is used in microphone path 2.</p> <p>"MIC ACTIVATION"</p> <p>BOTH MIKES ENABLED:</p> <p>Input /PTT1 (Pin P1-17) activates transmission from microphone path 1 and 2.</p> <p>Input /PTT2 (Pin J1-5) activates transmission from microphone path 2 and path 1.</p> <p>Input /IC (Pin P1-7) activates intercom from microphone path 1 and 2.</p> <p>BOTH MIKES DISABLED:</p> <p>Input /PTT1 (Pin P1-17) activates transmission only from microphone path 1</p> <p>Input /PTT2 (Pin J1-5) activates transmission only from microphone</p>

Display Contents	Description
	<p>path 2 Input /IC (Pin P1-7) activates intercom only from microphone path 1</p> <p>"OUTPUTS" HDPH 1 ENABLED Audio available on headphone 1 output (Pins P1-2/P1-3) HDPH 1 DISABLED No audio available on headphone 1 output. HDPH 2 ENABLED Audio is available on headphone 2 output (Pins P1-20/P1-22), speaker not available. HDPH 2 DISABLED No audio available on headphone 2 output, speaker not available. SPEAKER ENABLED Audio is available on speaker (Pins P1-1/P1-14), headphone 2 not available NONE No audio on headphone 2 output or speaker output. Note: Menu available on primary controller. Displayed only if MIKE_SW input (Pin J1-24) has inactive state.</p>
<div style="border: 1px solid black; padding: 5px; margin-bottom: 10px;"> <p>IN/OUT CFG 2</p> <p>MICROPHONE 1 <input type="text" value=""/></p> <ul style="list-style-type: none"> <input type="radio"/> STD 1 MIKE <input type="radio"/> STD 2 MIKE <input type="radio"/> STD 3 MIKE <input checked="" type="radio"/> DYN MIKE <input type="radio"/> NONE </div> <div style="border: 1px dashed black; padding: 5px;"> <p>MICROPHONE 2</p> <ul style="list-style-type: none"> <input type="radio"/> STD 1 MIKE <input type="radio"/> STD 2 MIKE <input type="radio"/> STD 3 MIKE <input type="radio"/> DYN MIKE <input checked="" type="radio"/> NONE <p>MIC ACTIVATION</p> <ul style="list-style-type: none"> <input checked="" type="checkbox"/> BOTH MIKES <p>OUTPUTS</p> <ul style="list-style-type: none"> <input checked="" type="checkbox"/> HEADPHONE 1 <input type="radio"/> HEADPHONE 1 <input checked="" type="radio"/> SPEAKER <input type="radio"/> NONE </div>	<p>"IN/OUT CFG 2": On "IN/OUT CFG 2" page the microphone inputs and headphone outputs for configuration CFG2 can be configured. This page is displayed only if MIKE_SW input (Pin J1-24) has active state. Please note when MIKE_SW connected in installation both configurations for IN/OUT CFG1 and IN/OUT CFG2 shall be configured. To scroll the page turn the "ROTARY ENCODER".</p> <p>"MICROPHONE 1" (at one time only one option can be selected): STD1 MIKE Standard microphone input 1 (Pins P1-18/ P1-8) is selected STD2 MIKE Standard microphone input 2 (Pins P1-9/ P1-8) is selected STD3 MIKE Standard microphone input 3 (Pins P1-19/ P1-8) is selected DYN MIKE Dynamic microphone input (Pins P1-6/ P1-5) is selected NONE No microphones is used in microphone path 1</p> <p>"MICROPHONE 2" (at one time only one option can be selected): STD1 MIKE Standard microphone input 1 (Pins P1-18/ P1-8) is selected STD2 MIKE Standard microphone input 2 (Pins P1-9/ P1-8) is selected STD3 MIKE Standard microphone input 3 (Pins P1-19/ P1-8) is selected</p>



Display Contents	Description
	<p>DYN MIKE Dynamic microphone input (Pins P1-6/ P1-5) is selected</p> <p>NONE No microphones is used in microphone path 2</p> <p>"MIC ACTIVATION"</p> <p>BOTH MIKES ENABLED: Input /PTT1 (Pin P1-17) activates transmission from microphone path 1 and 2 Input /PTT2 (Pin J1-5) activates transmission from microphone path 2 and 1 Input /IC (Pin P1-7) activates intercom from microphone path 1 and 2</p> <p>BOTH MIKES DISABLED: Input /PTT1 (Pin P1-17) activates transmission only from microphone path 1 Input /PTT2 (Pin J1-5) activates transmission only from microphone path 2 Input /IC (Pin P1-7) activates intercom only from microphone path 1</p> <p>"OUTPUTS"</p> <p>HDPH 1 ENABLED Audio available on headphone 1 output (Pins P1-2/P1-3)</p> <p>HDPH 1 DISABLED No audio is available on headphone 1 output.</p> <p>HDPH 2 ENABLED Audio is available on headphone 2 output (Pins P1-20/P1-22), speaker not available.</p> <p>HDPH 2 DISABLED No audio available on headphone 2 output, speaker not available.</p> <p>SPEAKER ENABLED Audio is available on speaker (Pins P1-1/P1-14), headphone 2 not available</p> <p>NONE No audio on headphone 2 output or speaker output.</p> <p>Note: Menu available on primary controller. Displayed only if MIKE_SW input (Pin J1-24) has inactive state.</p>

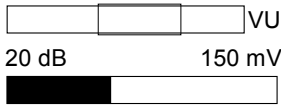

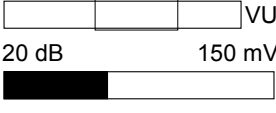
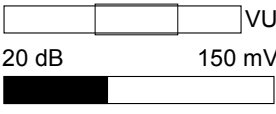
Display Contents	Description
	<p>"STD1 MIKE SENS": The sensitivity of standard microphone 1, "STD 1 MIKE SENS", input is adjustable within the range 9...1500 mV by turning the "ROTARY ENCODER".</p>

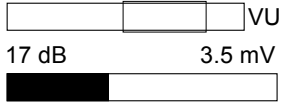
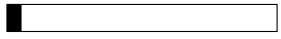
Display Contents	Description
<div style="border: 1px solid black; padding: 5px; margin-bottom: 10px;"> <p style="margin: 0;">STD1 MIKE SENS</p>  </div> <p>Note: This page is only displayed if : Standard Mike 2 input is selected in IN/OUT CFG1 and MIKE_SW input pin status is [Inactive] or Standard Mike 2 input is selected in IN/OUT CFG2 and MIKE_SW input pin status is [Active].</p>	<p>The factory setting is 110 mV.</p> <p>The VU meter displays the current signal level on the audio input and also displays the highest signal value for the last 3 seconds.</p> <p>When speaking normally into the microphone the bar graph should remain within the recommended predefined range</p> <p>Note: Adjust the microphone sensitivity by keeping the cockpit noise suppression as high as possible, this will ensure correct modulation.</p> <p>If the sensitivity is adjusted to a smaller value (e.g. 10 mV) the cockpit noises may become louder than for a higher adjustment (e.g. 100 mV). Otherwise, adjusting the sensitivity to a very high value (e.g. 1000 mV), the cockpit noise is very much reduced, but the modulation of the transmitter might be not sufficient.</p> <p>The installer shall perform a communication check after modification of this parameter. Recommended is to perform this check with and without a running engine.</p> <p>Note: Menu available on primary controller. For installations with high interferences it is recommended to use sensitivity level 27...1500 mV.</p>

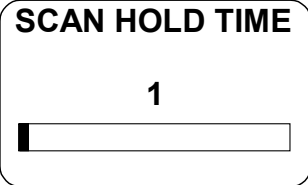
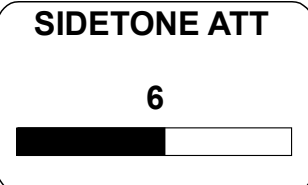
Display Contents	Description
<div data-bbox="236 432 544 616" style="border: 1px solid black; padding: 5px;"> <p>STD2 MIKE SENS</p>  </div> <p>Note: This page is only displayed if : Standard Mike 2 input is selected in IN/OUT CFG1 and MIKE_SW input pin status is [Inactive] or Standard Mike 2 input is selected in IN/OUT CFG2 and MIKE_SW input pin status is [Active].</p>	<p>"STD2 MIKE SENS": The sensitivity of standard microphone 2 input can be adjusted in range from 9...1500 mV by turning the "ROTARY ENCODER". The default setting is 110 mV. VU meter displays current value of audio level from standard microphone input 2 and displays the highest value of active audio level recorded during last 3 seconds. Correct sensitivity is achieved when you are speaking normally into the microphone, this is confirmed by the "Hold max level bar" remaining in "Recommended Range".</p> <p>Note: The microphone sensitivity shall be adjusted to achieve a correct modulation by keeping the cockpit noise suppression as high as possible. If the sensitivity value is very small (e.g. 10 mV) more cockpit noise will be heard than if the sensitivity value is set to a higher level (e.g. 100 mV). Alternatively if the sensitivity value is very high (e.g. 1000 mV) the cockpit noise will significantly be reduced but the modulation of the transmitter may not be sufficient. After modifying this parameter a communication check shall be done by the installer. It is recommended to perform this communication check with and without engine running.</p> <p>Note: Menu available on primary controller. For installations with high interference it is recommended to use sensitivity level 27...1500 mV.</p>
<div data-bbox="236 1317 544 1500" style="border: 1px solid black; padding: 5px;"> <p>STD3 MIKE SENS</p>  </div> <p>Note: This page is only displayed if : Standard Mike 3 input is selected in IN/OUT CFG1 and MIKE_SW input pin status is [Inactive] or Standard Mike 3 input is selected in IN/OUT CFG2 and MIKE_SW input pin status is [Active].</p>	<p>"STD3 MIKE SENS": The sensitivity of standard microphone 3 Input can be adjusted in range from 9...1500 mV by turning the "ROTARY ENCODER". The default setting is 110 mV. VU meter displays current value of audio level from standard microphone input 3 and displays the highest value of active audio level recorded during last 3 seconds. Correct sensitivity is achieved when you are speaking normally into the microphone, this is confirmed by the "Hold max level bar" remaining in "Recommended Range".</p> <p>Note: The microphone sensitivity shall be adjusted to achieve a correct modulation by keeping the cockpit noise suppression as high as possible. If the sensitivity value is very small (e.g. 10 mV) more cockpit noise will be heard than if the sensitivity value is set to a higher level (e.g. 100 mV). Alternatively if the sensitivity value is very high (e.g. 1000 mV) the cockpit noise will significantly be reduced but the modulation of the transmitter may not be sufficient. After modifying this parameter a communication check shall be done by the installer. It is recommended to perform this communication check with and without engine running.</p> <p>Note: Menu available on primary controller. For installations with high interferences it is recommended to use sensitivity level 27...1500 mV.</p>

Display Contents	Description
<div data-bbox="159 459 470 645" style="border: 1px solid black; padding: 5px;"> <p>DYN MIKE SENS</p>  </div> <p>Note: This page is only displayed if : Dynamic input is selected in IN/OUT CFG1 and MIKE_SW input pin status is [Inactive] or Dynamic Mike input is selected in IN/OUT CFG2 and MIKE_SW input pin status is [Active].</p>	<p>"DYN MIKE SENS": The sensitivity of the Dynamic Mike, "DYN MIKE SENS", input is adjustable within a range of 0.5...25 mV by turning the "ROTARY ENCODER".</p> <p>The factory setting is 3.5 mV.</p> <p>When speaking normally into the microphone the bar graph should remain within the recommended predefined range</p> <p>Note: The microphone sensitivity shall be adjusted to achieve a correct modulation by keeping the cockpit noise suppression as high as possible.</p> <p>If the sensitivity is adjusted to a smaller value (e.g. 1 mV) the cockpit noises may become louder than for a higher adjustment (e.g. 25 mV). Otherwise, adjusting the sensitivity to a very high value (e.g 25 mV), the cockpit noise is significantly reduced but the modulation of the transmitter may not be sufficient.</p> <p>The installer shall perform a communication check after modification of this parameter. Recommended is to perform this check with and without a running engine.</p> <p>Note: Menu available on primary controller. For installations with high interferences it is recommended to use sensitivity level 2...25 mV.</p>
<div data-bbox="159 1193 470 1379" style="border: 1px solid black; padding: 5px;"> <p>SPKR VOL SRC</p> <ul style="list-style-type: none"> <input type="radio"/> PRIMARY CH <input type="radio"/> SECONDARY CH <input checked="" type="radio"/> BOTH </div>	<p>"SPKR VOL SRC": One of the three following options may be selected for speaker volume source, "SPKR VOL SRC", by pressing the "STO" button:</p> <p>PRIMARY CH If "PRIMARY CH" is selected the speaker volume will be adjustable by AR6201-(X0X).</p> <p>SECONDARY CH If "SECONDARY CH" is selected the speaker volume will be adjustable by RCU6201.</p> <p>BOTH If "BOTH" is selected the speaker volume will be adjustable by the arithmetic average value from AR620X and RCU6201.</p> <p>Note: Menu available on primary controller. If optional second controller (RCU6201) is not available then SPKR VOLUME SOURCE shall be set to the PRIMARY CH</p>
<div data-bbox="159 1765 470 1951" style="border: 1px solid black; padding: 5px;"> <p>SQUELCH THR</p> <p align="center">6</p>  </div>	<p>"SQUELCH THR": The noise squelch threshold "SQUELCH THR" is adjustable within a range of 6...26 by turning the "ROTARY ENCODER".</p> <p>Minimum Adjustment of 6 means: Weak RF signals can trigger the Squelch threshold and the voice signal might be low combined with a noisy background.</p> <p>Maximum adjustment of 26 means: Only strong RF signals will trigger the Squelch threshold. The voice signal will be audible very clear with very low background noise.</p> <p>Weak RF signals may not trigger the Squelch threshold and therefore the audio may not be heard by the pilots.</p> <p>Note: Adjustment of the "SQUELCH THR" is available via the "PILOTS MENU" at any time.</p>

Display Contents	Description
	<p>Note: Menu available on primary controller.</p>
 <p>The screenshot shows a rounded rectangular box with the text "SCAN HOLD TIME" at the top. Below it is the number "1" centered. At the bottom is a horizontal progress bar with a small black segment on the left side.</p>	<p>"SCAN HOLD TIME": The "SCAN HOLD_TIME" is adjustable within the range of 1...60 seconds by turning the "ROTARY ENCODER".</p> <p>The default factory setting is 1.</p> <p>Note: Menu available on primary controller. For normal airborne operation it is recommended to leave the setting at 1.</p>
 <p>The screenshot shows a rounded rectangular box with the text "SIDETONE ATT" at the top. Below it is the number "6" centered. At the bottom is a horizontal progress bar with a larger black segment on the left side.</p>	<p>"SIDETONE ATT": The sidetone attenuation "SIDETONE ATT" is adjustable within the range 0...12 dB by turning the "ROTARY ENCODER".</p> <p>The attenuation relates to the intercom volume. 0dB = sidetone as loud as intercom signal. 12dB = sidetone signal 12 dB less than the intercom signal.</p> <p>Example: If the intercom volume is set to a very low value, then the sidetone volume will be reduced in relation to the intercom volume, irrespective of the sidetone value.</p> <p>The "SIDETONE ATT" parameter is an additional attenuation of the sidetone signal in transmit mode.</p> <p>Note: Menu available on primary controller.</p>
 <p>The screenshot shows a rounded rectangular box with the text "ERASE CHN MEM" at the top. Below it are two options: "NO" in a black box and "YES" in a white box.</p>	<p>"ERASE CHN MEM": The 620X transceiver provide two databases to store up to 99 VHF frequencies identified by channel numbers (CH01 to CH99). Both data bases, the "User Channels Database" and "Last Channels Database" can be erased.</p> <p>To erase the data bases;</p> <ol style="list-style-type: none"> 1. Select "YES" via the "ROTARY ENCODER" 2. Press the "STO" push-button to confirm the selection. <p>Note: Menu available on primary controller.</p>



Display Contents	Description																																													
<div style="border: 1px solid black; padding: 5px; text-align: center;"> <p>ERASE FRQ LAB</p>  </div>	<p>"ERASE FRQ LAB":</p> <p>The 620X transceiver provides a third database, "FRQUENCY LABELS DATABASE", containing 99 text labels of max 10 characters each. Text labels can be assigned to any of the frequencies (CH01 to CH99), the labels are stored manually.</p> <p>The "LABELS DATABASE" can be erased.</p> <p>To erase the data base;</p> <ol style="list-style-type: none"> Select "YES" via the "ROTARY ENCODER" Press the "STO" push-button to confirm the selection. <p>Note: Menu available on primary controller.</p>																																													
<div style="border: 1px solid black; padding: 5px;"> <p style="text-align: center;">FAIL LIST</p> <table style="width: 100%; border-collapse: collapse;"> <tr><td>P_NVRAM TEST</td><td style="text-align: right;">0</td><td style="border-left: 1px solid black; width: 15px;"></td></tr> <tr><td>P_INTERNAL IC</td><td style="text-align: right;">0</td><td style="border-left: 1px solid black;"></td></tr> <tr><td>P_RXS LOCK</td><td style="text-align: right;">0</td><td style="border-left: 1px solid black;"></td></tr> <tr><td>P_RECEIVER</td><td style="text-align: right;">0</td><td style="border-left: 1px solid black;"></td></tr> <tr><td colspan="3"> </td></tr> <tr><td>P_SUPP BLOCK</td><td style="text-align: right;">0</td><td style="border-left: 1px solid black;"></td></tr> <tr><td>P_OVER TEMP</td><td style="text-align: right;">0</td><td style="border-left: 1px solid black;"></td></tr> <tr><td>C_INTERNAL IC</td><td style="text-align: right;">0</td><td style="border-left: 1px solid black;"></td></tr> <tr><td>C_RXS LOCK</td><td style="text-align: right;">0</td><td style="border-left: 1px solid black;"></td></tr> <tr><td>C_TXS LOCK</td><td style="text-align: right;">0</td><td style="border-left: 1px solid black;"></td></tr> <tr><td>C_TX POWER</td><td style="text-align: right;">0</td><td style="border-left: 1px solid black;"></td></tr> <tr><td>C_SUPP BLOCK</td><td style="text-align: right;">0</td><td style="border-left: 1px solid black;"></td></tr> <tr><td>C_TX OVERLOAD</td><td style="text-align: right;">0</td><td style="border-left: 1px solid black;"></td></tr> <tr><td>C_OVER TEMP</td><td style="text-align: right;">0</td><td style="border-left: 1px solid black;"></td></tr> <tr><td>C_STUCK PTT</td><td style="text-align: right;">0</td><td style="border-left: 1px solid black;"></td></tr> </table> </div>	P_NVRAM TEST	0		P_INTERNAL IC	0		P_RXS LOCK	0		P_RECEIVER	0					P_SUPP BLOCK	0		P_OVER TEMP	0		C_INTERNAL IC	0		C_RXS LOCK	0		C_TXS LOCK	0		C_TX POWER	0		C_SUPP BLOCK	0		C_TX OVERLOAD	0		C_OVER TEMP	0		C_STUCK PTT	0		<p>"ERASE CHN MEM":</p> <p>This page automatically stores and displays information from all failures that occur during operation of the 620X.</p> <p>Used for trouble shooting and failure isolation.</p> <ol style="list-style-type: none"> The display can only show 4 monitored failures types (more are available). Move the slide bar via the "ROTARY ENCODER" To view additional failures. "0" means no failure were detected and stored. "1" means that a failure was detected once or several times and stored. <p>Note: Menu available on primary controller.</p>
P_NVRAM TEST	0																																													
P_INTERNAL IC	0																																													
P_RXS LOCK	0																																													
P_RECEIVER	0																																													
P_SUPP BLOCK	0																																													
P_OVER TEMP	0																																													
C_INTERNAL IC	0																																													
C_RXS LOCK	0																																													
C_TXS LOCK	0																																													
C_TX POWER	0																																													
C_SUPP BLOCK	0																																													
C_TX OVERLOAD	0																																													
C_OVER TEMP	0																																													
C_STUCK PTT	0																																													
<div style="border: 1px solid black; padding: 5px; text-align: center;"> <p>ERASE FAIL LIST</p>  </div>	<p>"ERASE FAIL LIST":</p> <p>To erase all stored failures.</p> <ol style="list-style-type: none"> Selecting "YES" via the "ROTARY ENCODER". Press the "STO" push-button to confirm. <p>Erasing the failure list should not be undertaken by the installer. The failure list will normally be deleted by factory or maintenance shop after a repair is completed</p> <p>Note: Menu available on primary controller.</p>																																													

Display Contents	Description
<p>RECALL DEF.</p> 	<p>"RECALL DEF:"</p> <p>The factory default settings are the settings of the device when it left the factory after production.</p> <p>To restore the factory settings;</p> <ol style="list-style-type: none"> 1. Select "YES" via the "ROTARY ENCODER". 2. PRESS the "STO" push-button to confirm. <p>Restoring the factory default settings will overwrite all previous and customized installation settings!</p> <p>Note: Menu available on primary controller.</p>

2.9. Factory Default Settings

Enabled
 Disabled
 Selected
 De-Selected

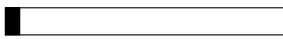
Setting name	Value
DEVICE INFO	
DIMMING INPUT	NONE
BRIGHTNESS	50%
MEMORY OPTIONS	<input checked="" type="checkbox"/> CHANNEL STORE <input checked="" type="checkbox"/> STORE LAST CHANNEL
MDE PAGES	<input checked="" type="checkbox"/> STANDBY FREQUENCY <input checked="" type="checkbox"/> BATTERY VOLTAGE <input checked="" type="checkbox"/> CHANNEL MEMORY
LOW BATT THR	10.5 V AR6201-(X2X) 21.0 V AR6201-(X1X)
CONFIG	<input type="checkbox"/> TANDEM <input type="checkbox"/> AUX_IN <input checked="" type="checkbox"/> AUTO ISOL IN TX <input type="checkbox"/> SCAN BEEP <input type="checkbox"/> FREQ CHANGE BEEP <input type="checkbox"/> SWAP MIKE IC
IN/OUT CFG1	MICROPHONE 1 <input checked="" type="radio"/> STD 1 MIKE <input type="radio"/> STD 2 MIKE <input type="radio"/> STD 3 MIKE <input type="radio"/> DYN MIKE <input type="radio"/> NONE MICROPHONE 2 <input type="radio"/> STD 1 MIKE <input type="radio"/> STD 2 MIKE <input type="radio"/> STD 3 MIKE <input checked="" type="radio"/> DYN MIKE <input type="radio"/> NONE MIC ACTIVATION <input checked="" type="checkbox"/> BOTH MIKES OUTPUTS <input checked="" type="checkbox"/> HEADPHONE 1 <input type="checkbox"/> HEADPHONE 2 <input checked="" type="radio"/> SPEAKER <input type="radio"/> NONE

Setting name	Value
IN/OUT CFG2	<p>MICROPHONE 1</p> <ul style="list-style-type: none"> <input checked="" type="radio"/> STD 1 MIKE <input type="radio"/> STD 2 MIKE <input type="radio"/> STD 3 MIKE <input type="radio"/> DYN MIKE <input type="radio"/> NONE <p>MICROPHONE 2</p> <ul style="list-style-type: none"> <input type="radio"/> STD 1 MIKE <input checked="" type="radio"/> STD 2 MIKE <input type="radio"/> STD 3 MIKE <input type="radio"/> DYN MIKE <input type="radio"/> NONE <p>MIC ACTIVATION</p> <ul style="list-style-type: none"> <input checked="" type="checkbox"/> BOTH MIKES <p>OUTPUTS</p> <ul style="list-style-type: none"> <input checked="" type="checkbox"/> HEADPHONE 1 <input checked="" type="radio"/> HEADPHONE 2 <input type="radio"/> SPEAKER <input type="radio"/> NONE
STD1 MIKE SENS	119 mV
STD2 MIKE SENS	119 mV
DYN MIKE SENS	3.5 mV
SPKR VOL SRC	<ul style="list-style-type: none"> <input type="radio"/> PRIMARY CH <input type="radio"/> SECONDARY CH <input checked="" type="radio"/> BOTH
SQUELCH THR	<p style="text-align: center;">12</p> 
SCAN HOLD TIME	<p style="text-align: center;">1</p> 
SIDETONE ATT	<p style="text-align: center;">6</p> 
EREASE CHANNEL MEM	<p>NO</p> <p>YES</p>
EREASE FREQUENCY LABELS	<p>NO</p> <p>YES</p>
FAIL LIST	
EREASE FAIL LIST	<p>NO</p> <p>YES</p>
RECALL DEF.	<p>NO</p> <p>YES</p>

visible depending on
 MIKE configuration of
 external MIKE Switch

2.10. Wiring Diagrams and Settings

SAFETY INSTRUCTIONS

Installation of the unit varies according to aircraft and equipment design. It is therefore only possible to provide general guidelines in this section.

2.10.1. Single Seat Glider

2.10.1.1. Installation Setup

Sub-Menu	Function: / Selection
"SPKR VOLUME SOURCE	PRIMARY CH
"IN/OUT CFG1":	<p>"MICROPHONE 1": NONE "MICROPHONE 2": DYN_MIKE "BOTH MIKES": Enabled "HEADPHONE 1": Enabled "SPEAKER": Enabled</p> <p>With /MIKE_SW not connected (/MIKE_SW input is set to Inactive state) it is only necessary to configure IN/OUT CFG1. If only headphone(s) are used, SPEAKER can be disabled by selecting NONE. If only speaker is used, disable HDPH 1.</p>
<div style="border: 1px solid black; padding: 5px;"> <p>DYN MIKE SENS</p> <div style="display: flex; align-items: center;"> <div style="border: 1px solid black; width: 100px; height: 15px; margin-right: 5px;"></div> <div style="margin-right: 5px;">VU</div> </div> <p>17 dB 3.5 mV</p> <div style="border: 1px solid black; width: 100px; height: 15px; background-color: black; margin-top: 5px;"></div> </div>	Adjust DYN MIKE SENS to proper level
<div style="border: 1px solid black; padding: 5px;"> <p>CONFIGURATION</p> <p><input type="checkbox"/> TANDEM</p> <p><input checked="" type="checkbox"/> AUX INPUT</p> <p><input checked="" type="checkbox"/> AUX AUTO MUTE</p> <p><input type="checkbox"/> AUTO ISOL IN TX</p> </div>	<p>If you want to use an auxiliary input we recommend to configure AUX AUTO MUTE In CONFIG menu set:</p> <p>AUX IN – ENABLE AUX AUTO MUTE - ENABLE</p>
"IN/OUT FG2"	N/A
Remarks	<p>Permanent speaker sign is visible on LCD screen. VOX operation suppressed.</p>

2.10.1.2. **Wiring Diagrams Single Seat Glider**

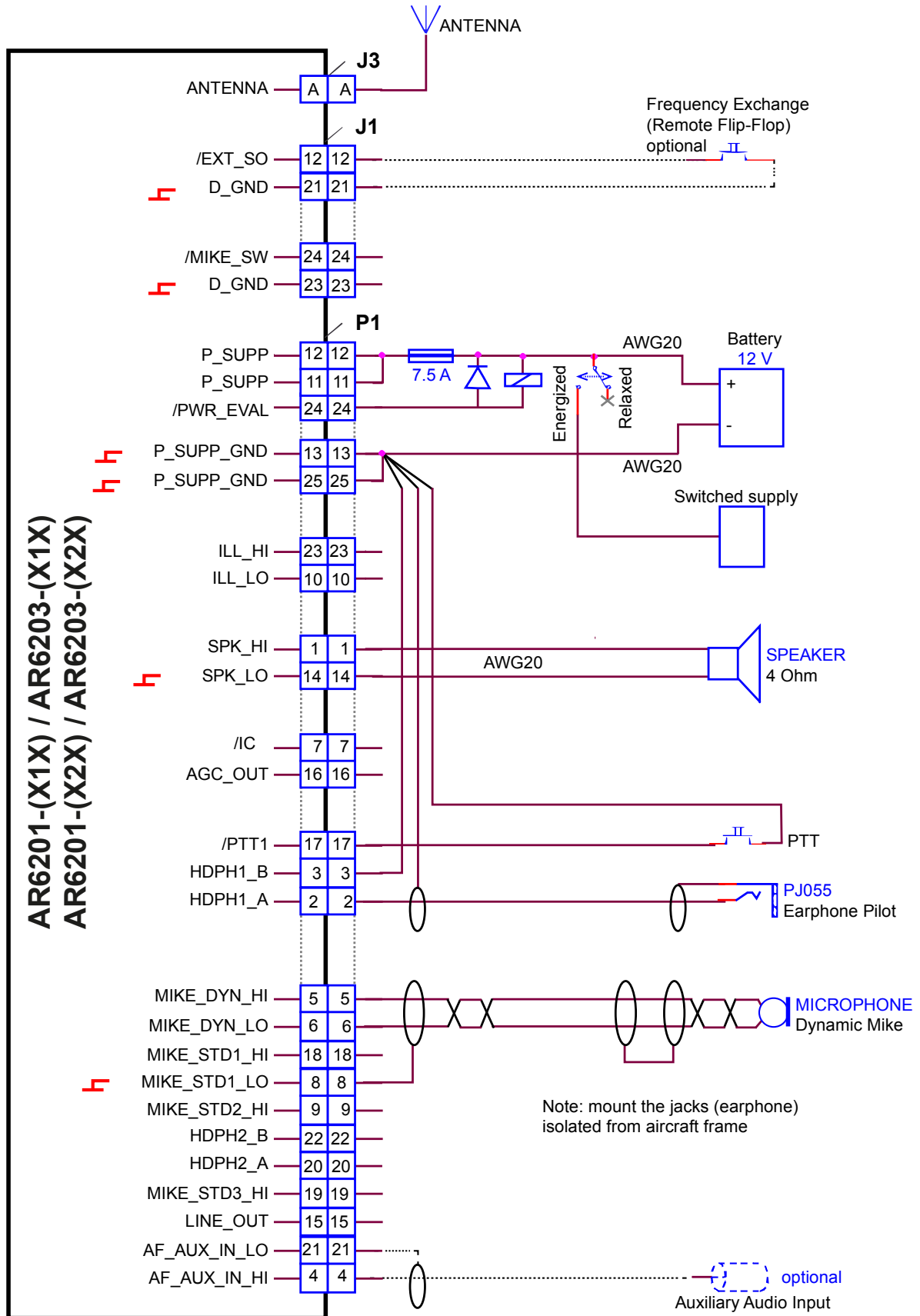

Figure 2-19: Wiring for Single Seat Glider

Note: Frequency exchange switch and switched supply relay are optional

2.10.1.3. **Wiring Diagrams Single Seat Glider 5-pol DIN Jack**

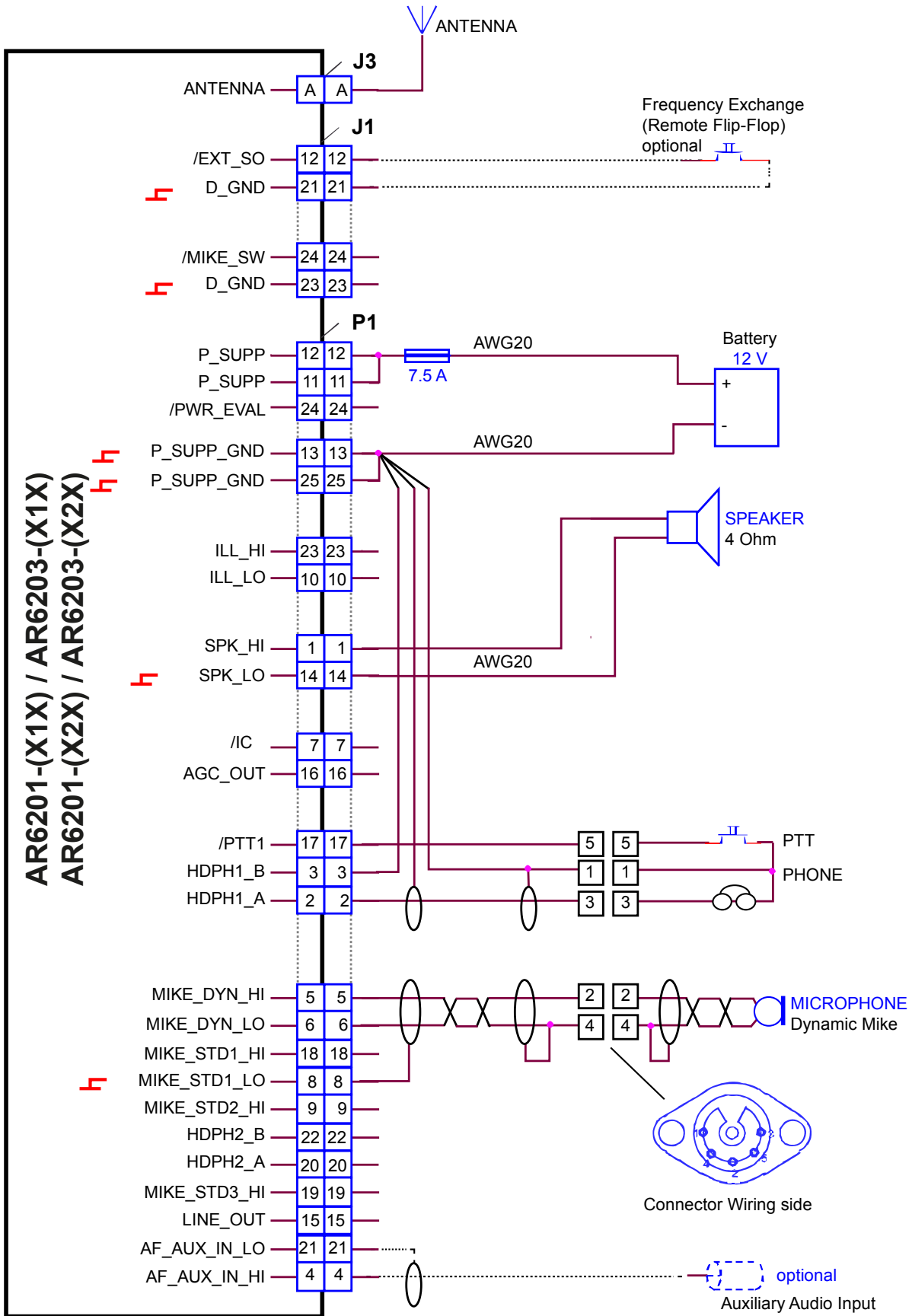

Figure 2-20: Wiring for Single Seat Glider (5-pol DIN Jack)

Note: Frequency exchange switch is optional

2.10.2. Twin Seat Motor Glider

2.10.2.1. Installation Setup

Sub-Menu	Function: / Selection
"SPKR VOLUME SOURCE	BOTH
"CONFIGURATION"	"SWAP MIKE IC" : Disabled
"IN/OUT CFG1" (/MIKE_SW open):	"MICROPHONE 1" : STD_1 MIKE "MICROPHONE 2" : NONE "BOTH MIKES" : Enabled "HEADPHONE 1" : Enabled "SPEAKER" : Disabled
"IN/OUT CFG2" (/MIKE_SW closed):	"MICROPHONE 1" : NONE "MICROPHONE 2" : DYN_MIKE "BOTH MIKES" : Enabled "HEADPHONE 1" : Enabled "SPEAKER" : Enabled
Remarks	The external switch (connected to pin J1-24 /MIKE_SW) has the following functions: Open: <ul style="list-style-type: none"> • Standard microphone is selected. • Speaker is disabled. • Intercom via VOX is possible. Closed: <ul style="list-style-type: none"> • Dynamic microphone is selected. • Speaker is enabled. • No Intercom via VOX is possible. • Permanent speaker sign is visible on LCD screen.

2.10.2.2. **Wiring Diagram Twin Seat Motor Glider**

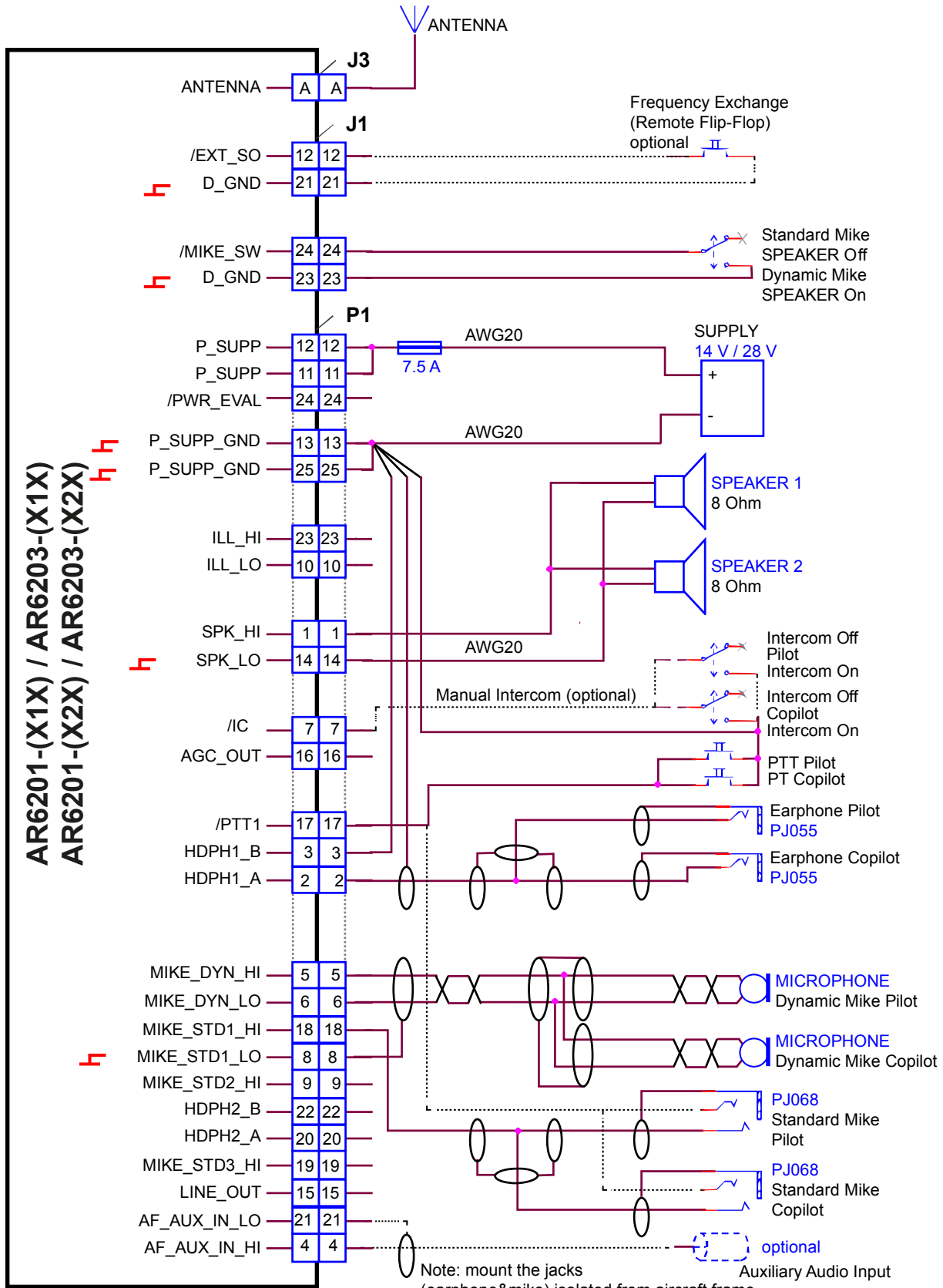

Figure 2-21: Wiring for Twin Seat Motor Glider

2.10.3. General Aviation (GA) Aircraft

2.10.3.1. Installation Setup (using Standard Microphones)

Sub-Menu	Function: / Selection
"SPKR VOLUME SOURCE	BOTH
"CONFIGURATION"	"SWAP MIKE IC" : Disabled
"IN/OUT CFG1" (/MIKE_SW open):	"MICROPHONE 1" : STD1_MIKE "MICROPHONE 2" : NONE "BOTH MIKES" : Disabled "HEADPHONE 1" : Enabled "SPEAKER" : Disabled
"IN/OUT CFG2" (/MIKE_SW closed):	"MICROPHONE 1" : STD1_MIKE "MICROPHONE 2" : NONE "BOTH MIKES" : Disabled "HEADPHONE 1" : Enabled "SPEAKER" : Enabled
Remarks	<p>The external switch (connected to pin J1-24 /MIKE_SW) has the following functions:</p> <p>Open:</p> <ul style="list-style-type: none"> • Speaker is disabled, • Intercom via VOX is possible. <p>Closed:</p> <ul style="list-style-type: none"> • Speaker is enabled • No intercom via VOX is possible • Permanent speaker sign is visible on LCD screen. • The standard microphone input is selected regardless of the position of the external switch.

2.10.3.2. **Wiring Diagram General Aviation GA Using Standard Microphones**

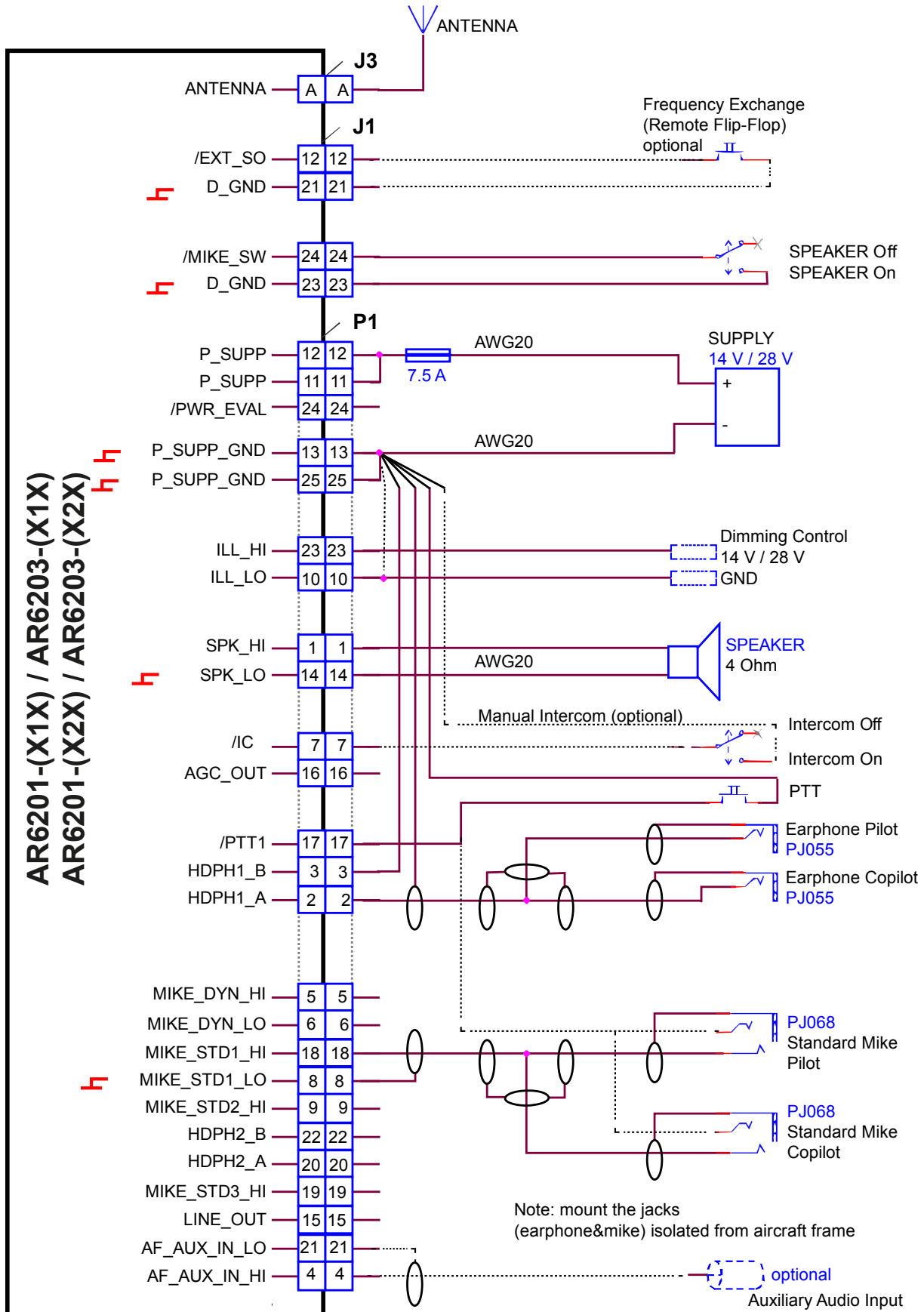

Figure 2-22: Wiring for Usage of Standard Hand Mikes, Earphones and Speaker

2.10.4. Individual Dual Headset Configuration (two IC Circuit)

2.10.4.1. Installation Setup

Sub-Menu	Function: / Selection
"SPKR VOLUME SOURCE	BOTH
"CONFIGURATION"	"SWAP MIKE IC" : Disabled
"IN/OUT CFG1" (/MIKE_SW open):	"MICROPHONE 1" : STD1_MIKE "MICROPHONE 2" : STD2_MIKE "BOTH MIKES" : Disabled "HEADPHONE 1" : Enabled "HEADPHONE 2" : Enabled "SPEAKER" : Disabled The standard microphone remains selected for both configurations
"IN/OUT CFG2" (/MIKE_SW closed):	"MICROPHONE 1" : STD1_MIKE "MICROPHONE 2" : STD3_MIKE "BOTH MIKES" : Enabled "HEADPHONE 1" : Disabled "SPEAKER" : Enabled
Remarks	The external switch (connected to pin J1-24 /MIKE_SW) has the following functions: Open: <ul style="list-style-type: none"> • Headset 1 for pilot selected (STD1) • Headset 2 for co-pilot selected (STD2) • Speaker is disabled, • Intercom via VOX is possible. Closed: <ul style="list-style-type: none"> • Headset 1 selected (STD1) • Headset 2 disconnected (STD2) • Hand mike selected (STD3) • Speaker is enabled • No intercom via VOX is possible <ul style="list-style-type: none"> • If PTT is active then speaker is muted.

2.10.4.2. **Wiring Diagram Individual Dual Headset Configuration - two IC Circuit**

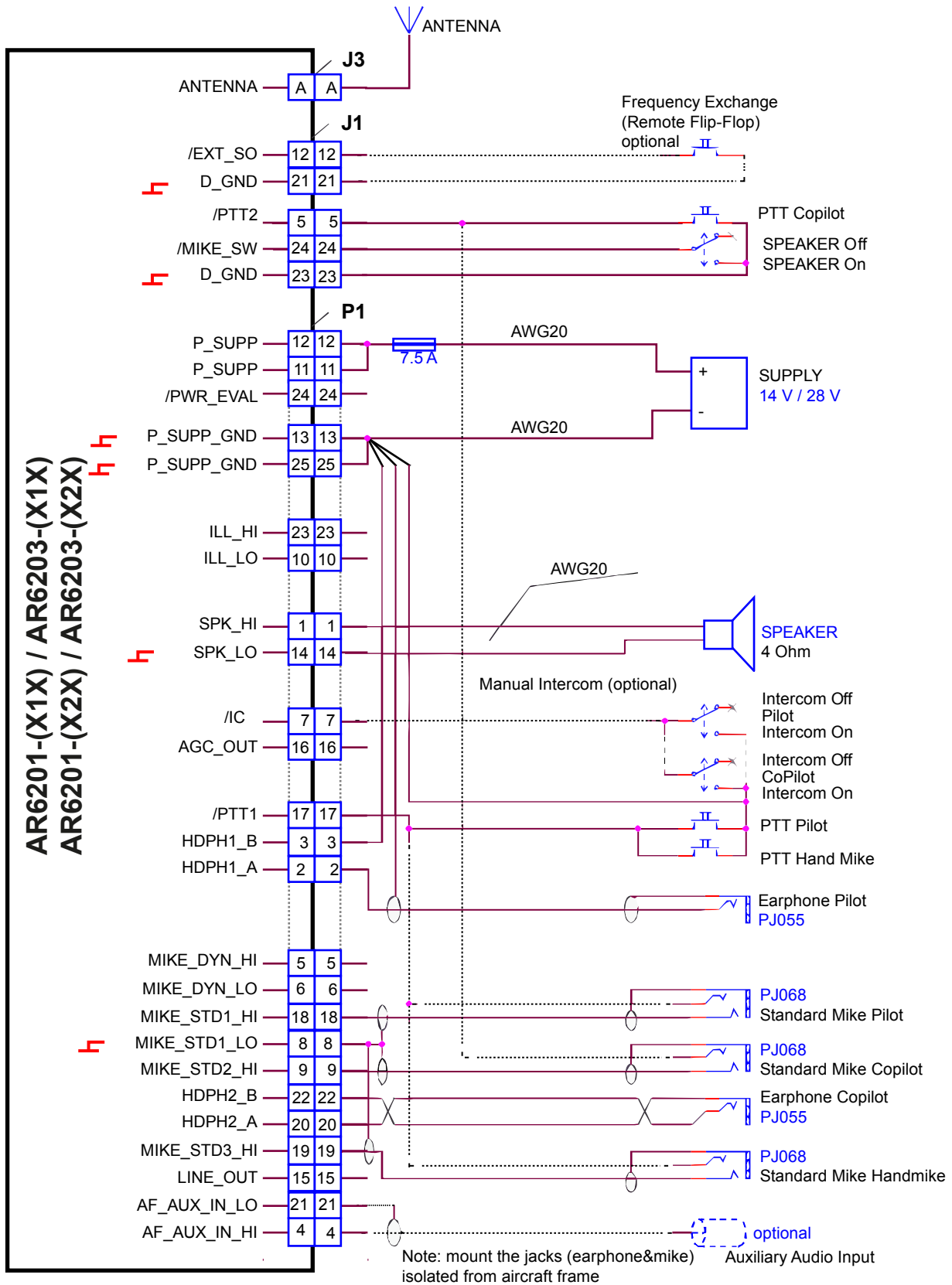

Figure 2-23: Dual wiring for Usage of Standard Hand Mikes, Earphones and Speaker

2.10.5. Twin Seat with AR620X Tandem Configuration

2.10.5.1. Installation Setup

Sub-Menu	Function: / Selection
"SPKR VOLUME SOURCE	BOTH
"CONFIGURATION"	"SWAP MIKE IC" : Disabled
"IN/OUT CFG1" (/MIKE_SW open):	"MICROPHONE 1" : STD1_MIKE "MICROPHONE 2" : NONE "BOTH MIKES" : Enabled "HEADPHONE 1" : Enabled "SPEAKER" : Disabled If only headphone(s) are used, SPEAKER can be disabled by selecting NONE. If only speaker is used, HDPH 1 can be disabled. The standard microphone remains selected for both configurations
"IN/OUT CFG2" (/MIKE_SW closed):	"MICROPHONE 1" : STD1_MIKE "MICROPHONE 2" : NONE "BOTH MIKES" : Enabled "HEADPHONE 1" : Enabled "SPEAKER" : Enabled
Remarks	The external switch (connected to pin J1-24 /MIKE_SW) has the following functions: Open: <ul style="list-style-type: none"> • Headset 1 for pilot selected • Headset 2 for co-pilot selected • Speaker is disabled, • Intercom via VOX is possible. Closed: <ul style="list-style-type: none"> • Headset 1 selected (STD1) • Headset 2 disconnected (STD2) • Hand mike selected (STD3) • Speaker is enabled • No intercom via VOX is possible <ul style="list-style-type: none"> • If PTT is active then speaker is muted.

2.10.5.2. **Wiring Diagram Twin Seat with AR620X Tandem Configuration**

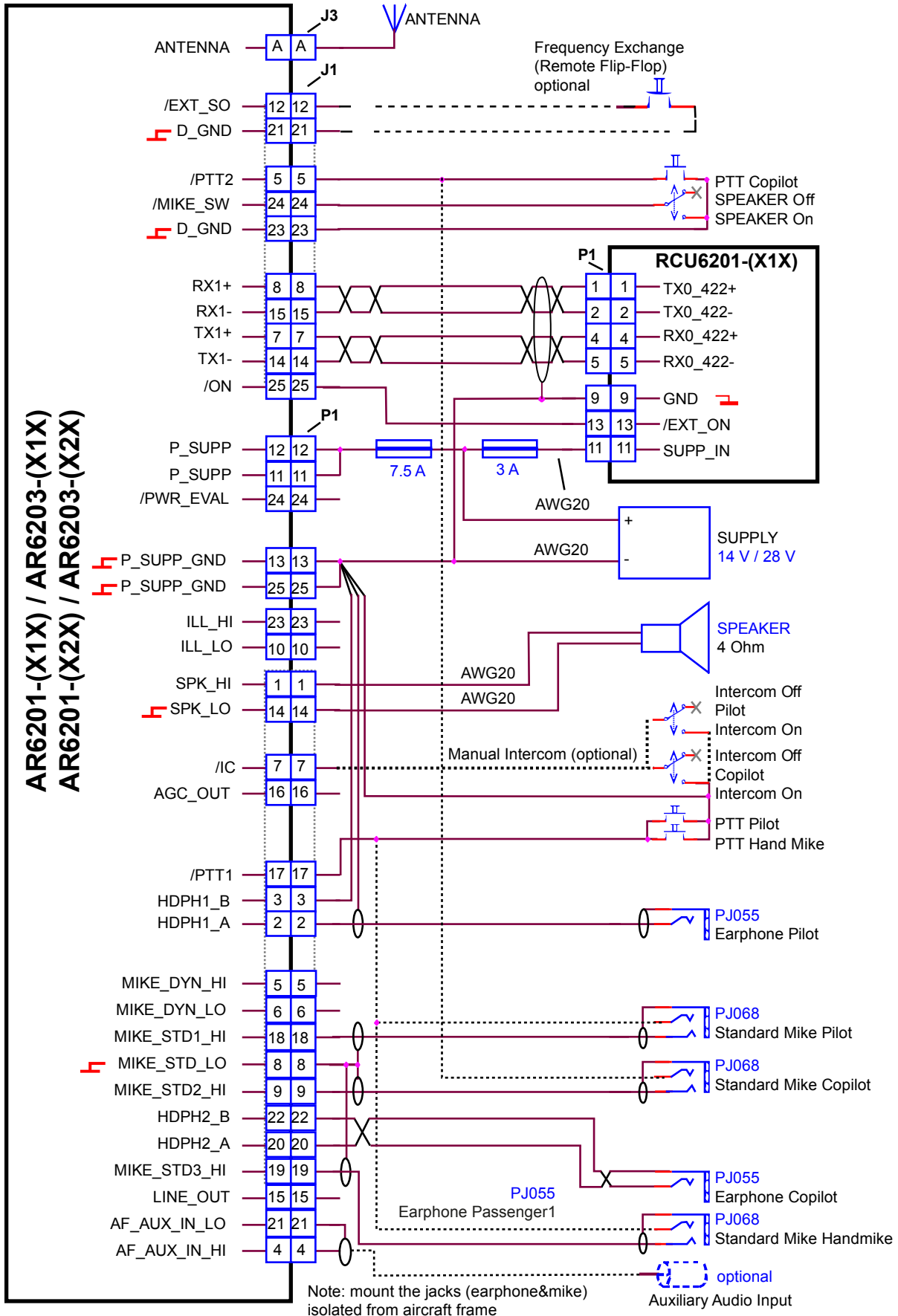

Figure 2-24: Wiring for Twin Seat with AR6201 Tandem Configuration

2.10.6. Aircraft with four Seats (no TANDEM)

2.10.6.1. Installation Setup

Sub-Menu	Function: / Selection
"SPKR VOLUME SOURCE	BOTH
"CONFIGURATION"	"SWAP MIKE IC" : Disabled
"IN/OUT CFG1" (/MIKE_SW open):	"MICROPHONE 1" : STD1_MIKE "MICROPHONE 2" : STD3_MIKE "BOTH MIKES" : Enabled "HEADPHONE 1" : Disabled "SPEAKER" : Enabled If only headphone(s) are used, SPEAKER can be disabled by selecting NONE. If only speaker is used, HDPH 1 can be disabled. The standard microphone remains selected for both configurations
"IN/OUT CFG2" (/MIKE_SW closed):	"MICROPHONE 1" : STD1_MIKE "MICROPHONE 2" : STD2_MIKE "BOTH MIKES" : Disabled "HEADPHONE 1" : Enabled "HEADPHONE 2" : Enabled "SPEAKER" : Disabled
Remarks	The external switch (connected to pin J1-24 /MIKE_SW) has the following functions: Open: <ul style="list-style-type: none"> • Headset 1 and 2 for pilot and co-pilot selected • Headset 3 and 4 for passengers selected • Speaker is disabled, • Intercom via VOX is possible. Closed: <ul style="list-style-type: none"> • Headset 1 and 2 for pilot and co-pilot selected • Headset 3 and 4 disconnected • Hand mike selected (STD3) • Speaker is enabled • No intercom via VOX is possible <ul style="list-style-type: none"> • If PTT is active then speaker is muted.

2.10.6.2. **Wiring Diagram Aircraft with four Seats - no TANDEM**

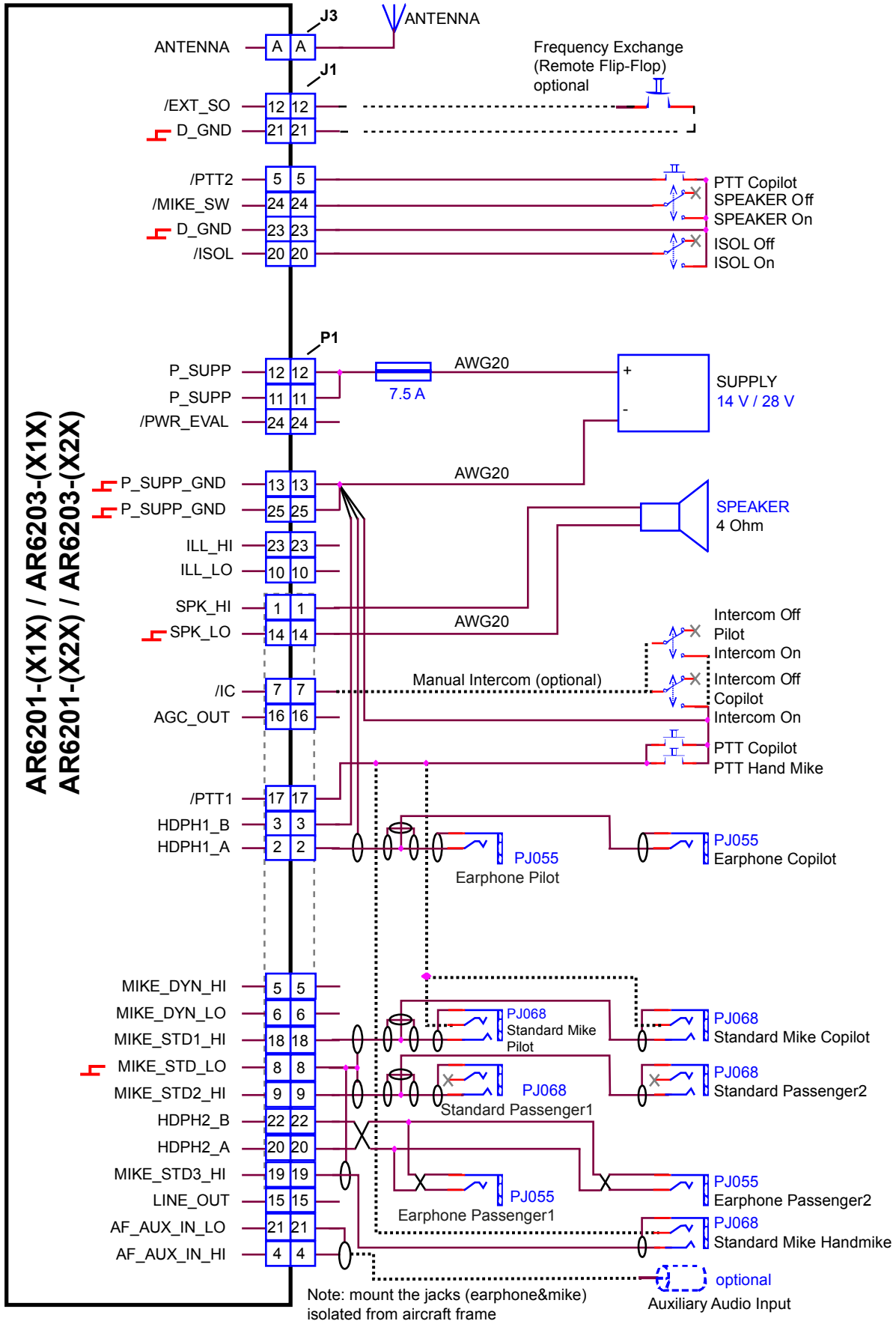

Figure 2-25: Wiring for Aircraft with Four Seats (no TANDEM)

2.10.7. Installation with RT6201 and RCU6201

RT6201 with primary controller RCU6201 can be used in all presented installation wirings. RT6201 with RCU6201 replace a AR620X. The connection between RT6201 and RCU6201 is shown in the wiring diagram below.

2.10.7.1. Wiring Diagram with RT6201 and RCU6201

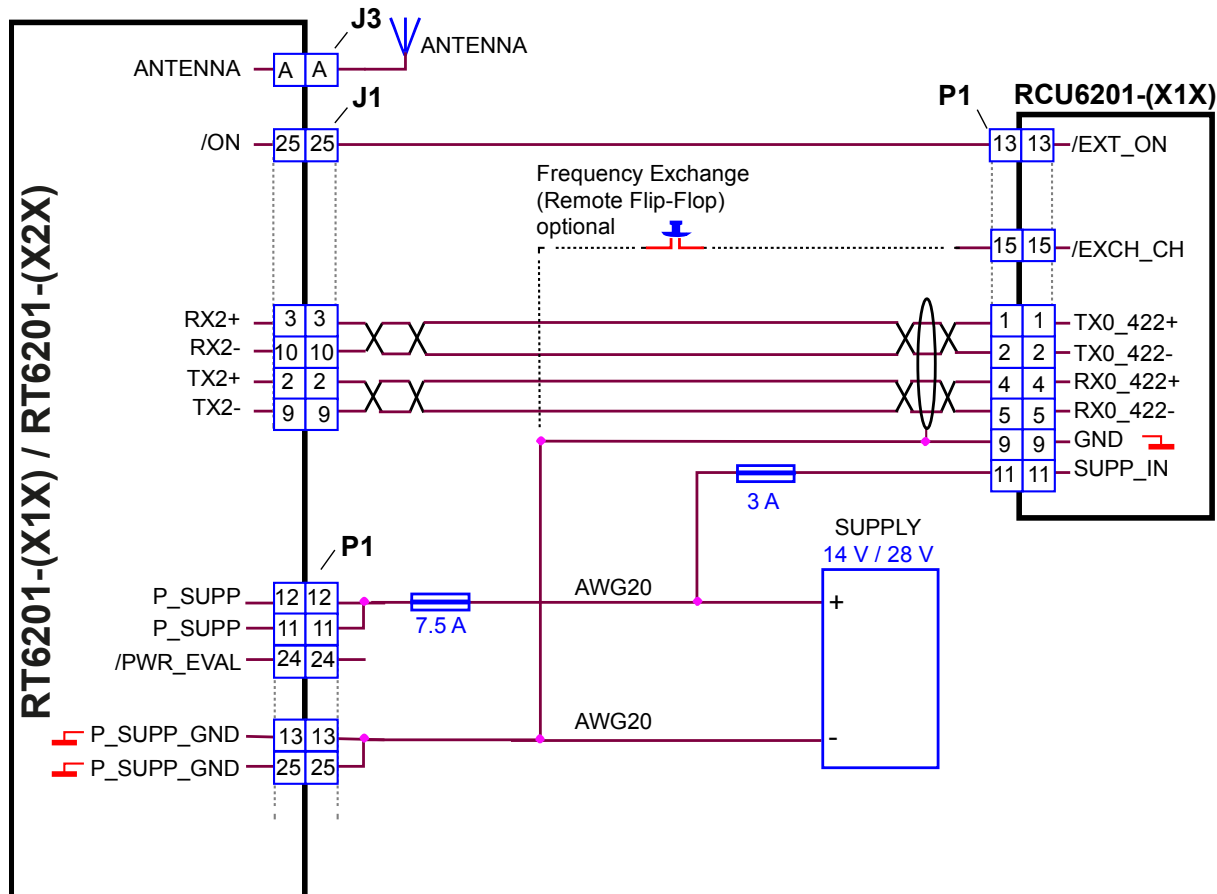

Figure 2-26 Wiring for RT6201 with RCU6201 as Primary Controller

2.10.8. Aircraft with Intercom System

2.10.8.1. *Installation Setup*

Sub-Menu	Function: / Selection
"SPKR VOLUME SOURCE	BOTH
"CONFIGURATION"	"SWAP MIKE IC" : Disabled
"IN/OUT CFG1":	"MICROPHONE 1" : STD1_MIKE "MICROPHONE 2" : NONE "BOTH MIKES" : Enabled "HEADPHONE 1" : Enabled "SPEAKER" : Disabled
"IN/OUT FG2"	"MICROPHONE 1" : STD1_MIKE "MICROPHONE 2" : NONE "BOTH MIKES" : Enabled "HEADPHONE 1" : Enabled "SPEAKER" : Enabled
Remarks	The same configuration applies for balanced and unbalanced wiring.

2.10.8.2. **Wiring Diagram Aircraft with Intercom System unbalanced**

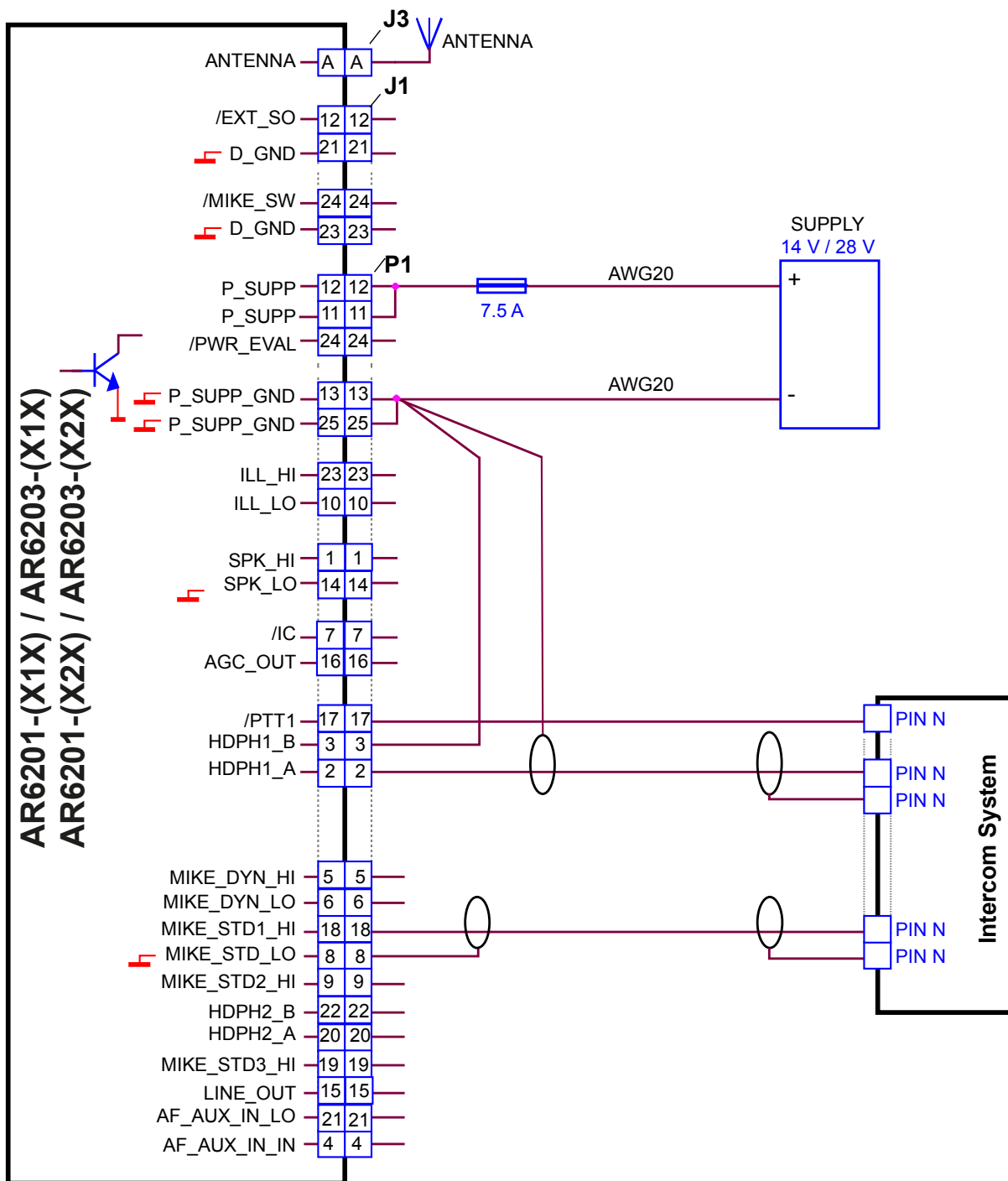

Figure 2-27: Wiring for Aircraft with Intercom System (unbalanced)

2.10.8.3. **Wiring Diagram Aircraft with Intercom System Balanced**

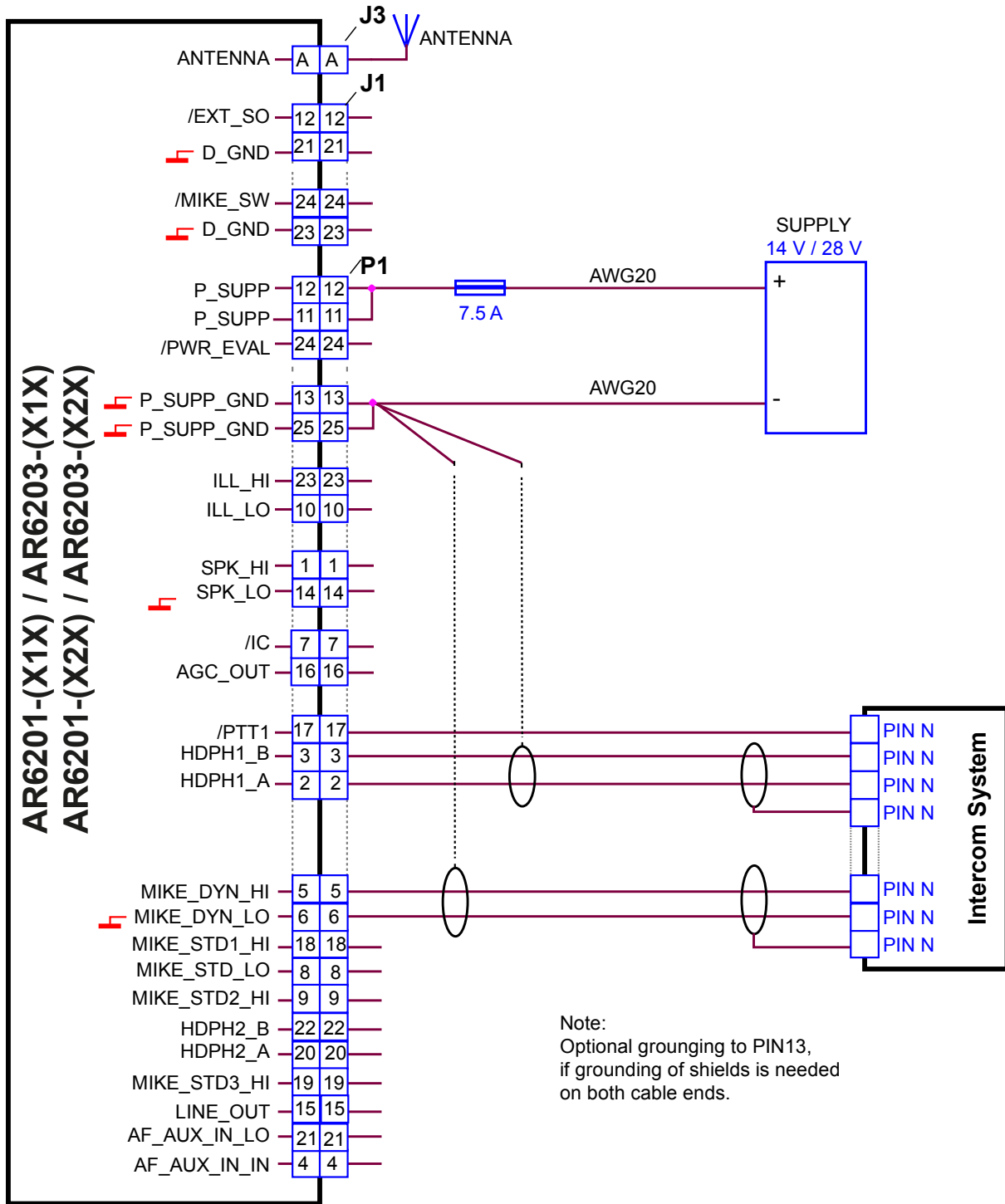

Figure 2-28: Wiring for Aircraft with Intercom System (balanced)

2.10.9. Twin Seat with RT6201 Tandem Configuration

2.10.9.1. Installation Setup

Sub-Menu	Function: / Selection
"SPKR VOLUME SOURCE	BOTH
"CONFIGURATION"	"SWAP MIKE IC" : Disabled
"IN/OUT CFG1" (/MIKE_SW open):	"MICROPHONE 1" : STD1_MIKE "MICROPHONE 2" : NONE "BOTH MIKES" : Enabled "HEADPHONE 1" : Enabled "SPEAKER" : Disabled If only headphone(s) are used, SPEAKER can be disabled by selecting NONE. If only speaker is used, HDPH 1 can be disabled. The standard microphone remains selected for both configurations
"IN/OUT CFG2" (/MIKE_SW closed):	"MICROPHONE 1" : STD1_MIKE "MICROPHONE 2" : NONE "BOTH MIKES" : Enabled "HEADPHONE 1" : Enabled "SPEAKER" : Enabled
Remarks	The external switch (connected to pin J1-24 /MIKE_SW) has the following functions: Open: <ul style="list-style-type: none"> • Headset 1 for pilot selected • Headset 2 for co-pilot selected • Speaker is disabled, • Intercom via VOX is possible. Closed: <ul style="list-style-type: none"> • Headset 1 selected (STD1) • Headset 2 disconnected (STD2) • Hand mike selected (STD3) • Speaker is enabled • No intercom via VOX is possible <ul style="list-style-type: none"> • If PTT is active then speaker is muted.

2.10.9.2. **Wiring Diagram Twin Seat with RT6201 Tandem Configuration**

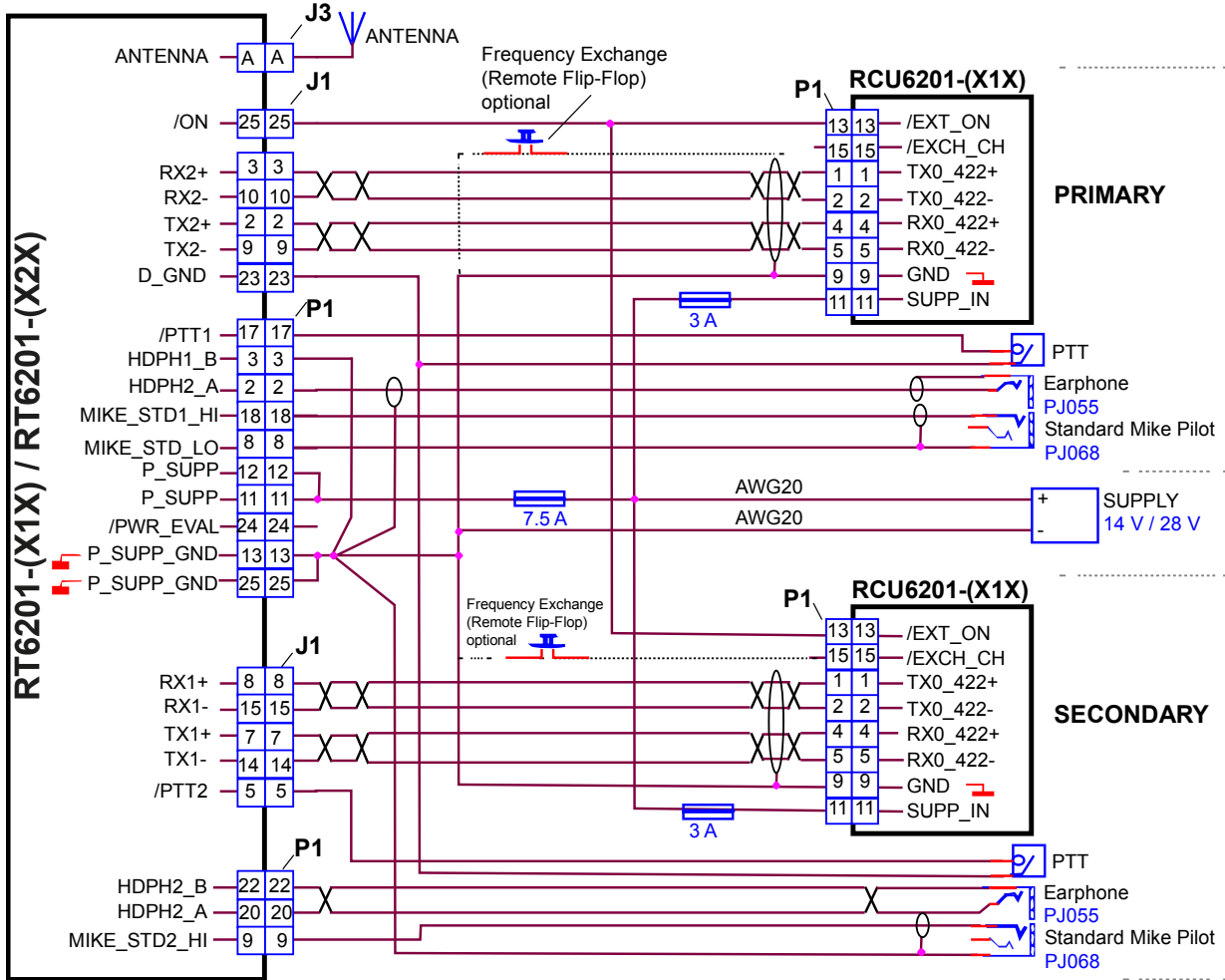

Figure 2-29: Wiring for Twin Seat with RT6201 Tandem Configuration

Note: Setup configuration only via Primary RCU

2.11. Predesigned Cable Harness

2.11.1. 1K065 for General Aviation

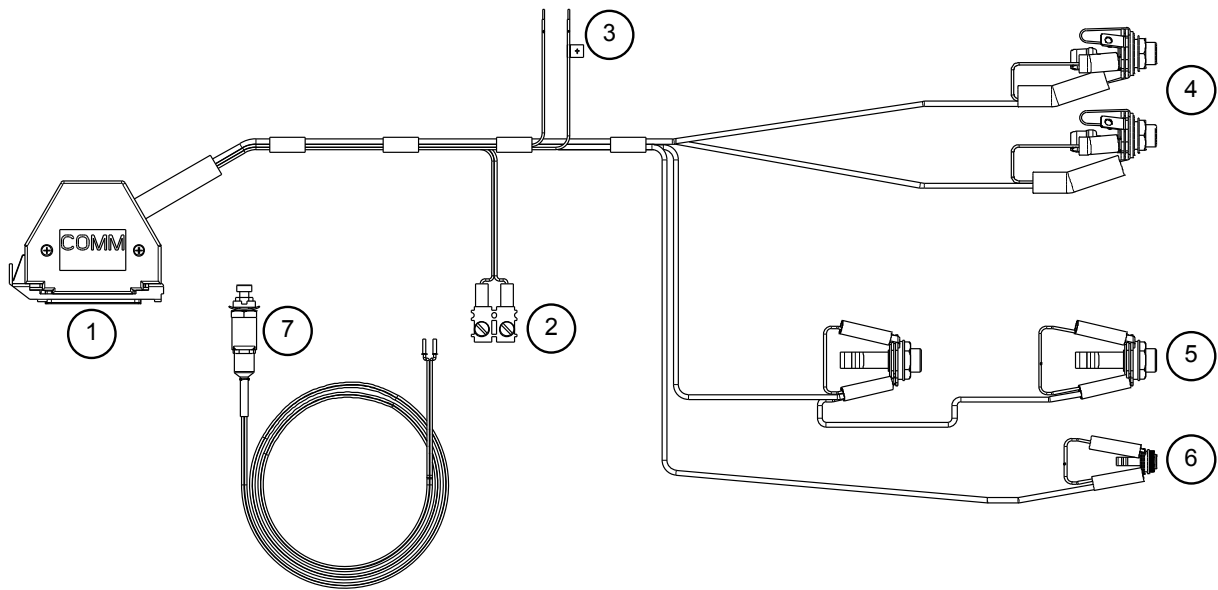

Figure 2-30: Cable harness 1K065

	Connector
1	Dsub connector (to P1 unit connector)
2	Connector for PTT switch (see 7)
3	Power supply lines
4	2x Microphone, jack socket PJ68
5	2x Phone, jack socket PJ55
6	Audio input, jack socket 3.5 mm
7	PTT switch

Order code see: "Accessories", page 30.

2.11.2. 1K062 (Open Cable Ends)

The cable harness 1K062 has open cable ends, the basic construction is like type 1K065.

2.12. Retrofitting AR4201 with AR6201

In most cases, a retrofit of the AR4201 with an AR6201 will not cause any problems.

However, in a few cases differences may occur due to pin incompatibility.

Connecting the AR6201 to an AR4201 wiring will NOT damage the AR6201 or the aircraft installation.

2.12.1. Pin Compatibility AR4201 - AR6201

Pin No.	AR4201 Pin Name	AR4201 Function	AR6201 Pin Name	AR6201 Function	Full compatible
P1-1	AF-ASYM	Speaker output, unbalanced	SPK_HI	Speaker output, unbalanced	Yes
P1-2	AF-HI	Headphone output, balanced	HDPH1_A	Headphone 1 output, balanced	Yes
P1-3	AF-LO	Headphone output, balanced	HDPH1_B	Headphone 1 output, balanced	Yes
P1-4	AFAUX	Auxiliary audio input, unbalanced	AF_AUX_IN_HI	Auxiliary audio input, unbalanced	Yes
P1-5	MIKE DYN	Dynamic microphone input, high side, unbalanced	MIKE_DYN_HI	Dynamic microphone input, high side, balanced	Yes
P1-6	MIKE GROUND	Ground for dynamic microphone, unbalanced	MIKE_DYN_LO	Dynamic microphone input, low side, <u>balanced</u>	No
P1-7	IC	Intercom input	IC	Intercom input	Yes
P1-8	TEMS1	Input for temperature sensor	MIKE_STD_LO	Ground	No
P1-9	RXD	RS232-serial-data-line	MIKE_STD2_HI	Standard microphone 2 input, high side, unbalanced	No
P1-10	-ILLUMINATION	Illumination, low side	ILL_LO	Illumination, low side	Yes
P1-11	+13.75 V	Positive power supply	P_SUPP	Positive power supply	Yes
P1-12	+13.75 V	Positive power supply	P_SUPP	Positive power supply	Yes
P1-13	GROUND	Power supply return / Ground	P_SUPP_GND	Power supply return / Ground	Yes
P1-14	AF GND MIKE STD GND	Ground	SPK_LO	Ground	Yes
P1-15	AFCU	Normally not used in installation	LINE_OUT	Normally not used in installation	No
P1-16	AGC/AFWB	Normally not used in installation	AGC_OUT	Normally not used in installation	No
P1-17	PTT	Press to talk	/PTT	Press to talk	Yes
P1-18	MIKE STD1	Standard microphone input, high side, unbalanced	MIKE_STD1_HI	Standard microphone 1 input, high side, unbalanced	Yes
P1-19	CODE PIN	Used for identification of the connection	MIKE_STD3_HI	Standard microphone 3 input, high side, unbalanced	No
P1-20	TEMS2	Headphone 2	HDPH2_A	Headphone 2 output, balanced	No
P1-21	GNDDATA	Ground	AF_AUX_IN_LO	no Ground	No
P1-22	TXD	RS232-serial-data-line	HDPH2_B	Headphone 2 output, balanced	No
P1-23	ILLUMINATION	Illumination, high side	ILL_HI	Illumination, high side	Yes

Pin No.	AR4201 Pin Name	AR4201 Function	AR6201 Pin Name	AR6201 Function	Full compatible
P1-24	+13.75V SWITCHED	Power on monitor <u>Switched positive power supply.</u>	/PWR_EVAL	Power on monitor, <u>open collector output,</u> conducting to GND for "On"	No
P1-25	GROUND	Power supply return / Ground	P_SUPP_GND	Power supply return / Ground	Yes

2.12.2. Dynamic Microphone Input

Retrofitting an AR4201 with the AR6201 in a typical glider installation with a dynamic microphone is shown below:

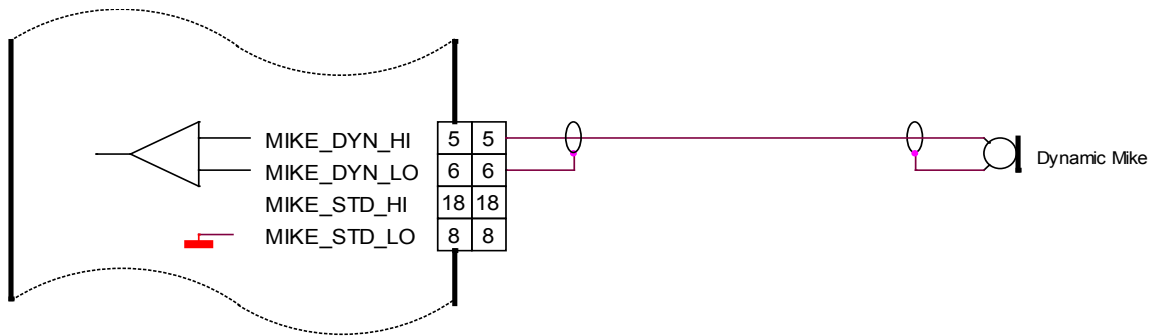

Figure 2-31: AR6201 with wiring interface for AR4201

Connect the cable shielding to pin P1-6, which is the low side input for dynamic microphone. Because in AR6201 this input is balanced, the cable shield is no longer connected to ground (unlike it was with the AR4201). In most cases, it is not a problem.

If interference with the microphone signal does occur, it is recommended to carry out the following modification:

Connect Pin P1-6 with Pin P1-8 (the cable shield is grounded). See Figure below.

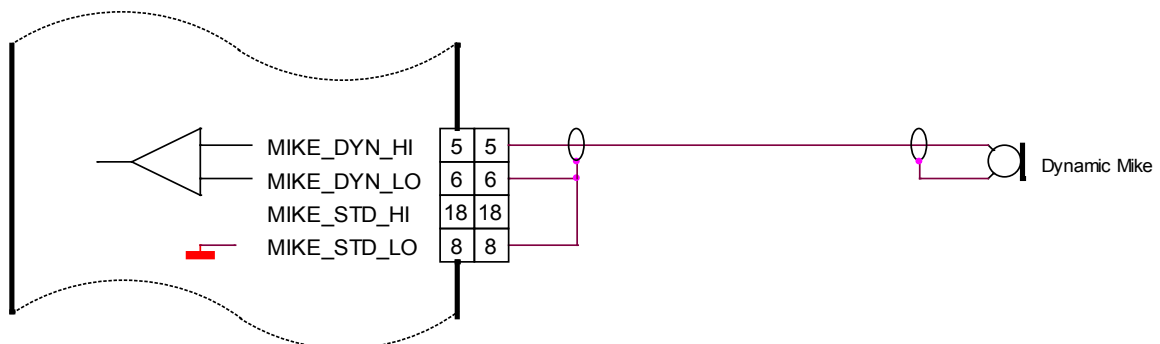

Figure 2-32: Modified dynamic microphone wiring interface for AR6201

2.12.3. Temperature Sensor

The AR6201 has no temperature sensor input. Remove wire from pin P1-8 and pin P1-20.

2.12.4. RS-232 Interface

The AR6201 has no RS232 interface for remote control. Remove wire from pin P1-9 and pin P1-22.

2.12.5. AFCU/AGC/AFWB

Not used in aircraft installations, remove pins P1-15 and pin P1-16.

2.12.6. CPIN (if Installed)

No influence in retrofit installation, please remove coding cap from the connector hole.

2.12.7. +13.75 V Switched (AR4201) - PWR_EVAL (AR6201)

The AR6201 provides on pin P1-24 a low signal when the unit is switched on and a high impedance signal, when switched off.

Note: This is not compatible to the AR4201, which provided a positive power supply when switched on and high impedance when switched off.

In cases where slave equipment needs to be switched ON/OFF in sync with the AR6201 connect a relay to pin P1-24.

2.13. Post Installation Tests

Note: It is assumed that the "Installation Setup" (see "Installation Setup", page 53) has been done before the Post Installation Tests will be carried out.

Once the 620X is installed, complete a test procedure to verify system functionality. Ensure compliance with authority required procedures. Refer to the installation order of the minor change document or use an own approved test protocol for VHF units. The following chapter below provides guidance for such tests.

2.13.1. Mechanical Installation and Wiring Check

- Verify all cables are fixed securely and shields connected properly to signal ground.
- Check the movement of aircraft controls to verify there is no interference.
- Verify all screws are tight and the connectors on the rear side of the unit are secured.

2.13.2. Power Supply

- Check the power supply lines and confirm correct polarity.
- Confirm that the aircraft power supply is within the specified limits, with and without a running engine.

2.13.3. Receiver / Transmitter Operation

- Power up the 620X and tune it to a local station for a communication test.
- Verify that the receiver output produces a clear and readable audio and ask the local station for proper readability for the transmit signal of the 620X.
- Repeat this communication test with an airborne station within \approx 20-40 NM (Nautical Miles).

2.13.4. Antenna Check

- Check the VSWR (voltage standing wave ratio) over the complete frequency band (e.g. by using a VHF Reflection-Coefficient Meter).
The VSWR ratio should be less than 2:1 and is not acceptable when exceeding 3:1.

2.13.5. Interference Check

- Check the 620X while engine is running and all other avionics/ electrical systems on the aircraft are powered, to verify that no significant interference exists.
- Check also that the 620X does not cause significant interference with other systems.

The installer's standard test procedure may be used for the interference check and the table below can be taken as a reference. Depending on the individual avionic systems installed in the aircraft, it might be necessary to extend the following checklist accordingly.

Aircraft System	Function	
	OK	NOT OK
DME		
Audio		
Generators / Inverters		
GPS System		
Compass 1		
ADF		
VHF / NAV1 all channels		
VHF / NAV 2 all channels		
Marker Beacon		
Motor(s)		
Engine Instruments		
Stormscope		
Transponder		
Air Data Computer		
Autopilot and Servos		

- Power the GPS and make sure that not less than 5 satellites are tracked.
- Check the interference between the VHF-COM and the GPS receiver (when activated in NAV mode).
- Select the following channels/frequencies on the 620X and on each frequency stay in TX and RX mode for at least 30 seconds.
- Verify that GPS integrity flag is always out of view.

Channel	Frequency (MHz)
121.140	121.1416
121.150	121.1500
121.155	121.1500
121.160	121.1583
121.165	121.1666
121.175	121.1750
121.180	121.1750
121.185	121.1833
121.190	121.1916
121.200	121.2000
121.205	121.2000
121.210	121.2083
131.240	131.2416
131.250	131.2500
131.255	131.2500
131.260	131.2583
131.265	131.2666
131.275	131.2750
131.280	131.2750
131.285	131.2833
131.290	131.2916
131.300	131.3000
131.305	131.3000
131.310	131.3083

For the remaining avionic equipment repeat all interference checks during a flight and include all equipment not previously checked out on ground. A communication performance check in the low, mid and high frequency band of the 620X should be included.

- Verify the receiver output produces a clear and understandable audio output.
- Verify the transmitter by contacting another station and getting a report of reliable communications.
- Perform the range check with a station at least 100 m from your own position.
- Check the intercom function by talking into the microphone, while the engine is running at cruising rpm. You should hear yourself and/or your co-pilot loud and clear.
- Switch "ON" the squelch and check that the normal radio noise, without a present carrier signal, it will be constantly suppressed. The threshold of the squelch can be set in the pilots menu.

2.13.6. Flight Test Check

It is highly recommended to perform flight test as final installation verification. The performance of the 620x may be verified by contacting a ground station at a range of at least 50 NM while maintaining an appropriate altitude and over all normal flight attitudes.

- Check the performance in the low, mid and high band frequencies.

2.14. Trouble Shooting

Problem	Possible Reason	Proposed Solution
No Intercom function. (You can't hear yourself when talking into the microphone).	VOX is switched "OFF", or adjusted to a too high value.	Adjust the VOX to a lower value. A value of "-15" is suitable in most cases. Refer to "Installation Setup", page 53).
	The intercom volume adjusted to a too low value.	Adjust the intercom volume to a higher value. A value of "37" produces already a quite loud intercom signal. Refer to "Installation Setup", page 53).
	The sensitivity of the microphone input is not sufficient. The level is adjusted to a too high value.	Adjust the sensitivity of the microphone input to a lower value. For most common avionic headsets a setting of 50... 120 mV is sufficient. Refer to "Installation Setup", page 53).
VOX threshold is not adjustable. VOX is always off.	VOX is inoperative, because speaker is on.	Switch speaker to "OFF". Refer to "Installation Setup", page 53).
Too high cabin noise during intercom / transmit operation.	The sensitivity of the microphone input is too sensitive.	Adjust the microphone sensitivity to a higher value to ensure the cabin noise relatively reduces. Recheck transmit operation and/or Intercom function. Refer to "Installation Setup", page 53).
No Speaker output.	Speaker is switched off	Switch Speaker "ON". Refer to "Installation Setup", page 53).
The noise suppression function of the squelch is not working. (Receiver noise is always present).	Some avionic (especially non ETSO/TSO approved avionic) can produce quite high electromagnetic interference, which is receiving by the AR6201-().	Reduce the interference emitted by the avionic around by improving shielding, distance or grounding. The interference may also been suppressed by adjusting the squelch to a higher value. Refer to "Installation Setup", page 53). Note, that a higher value will cause a reduced sensitivity.
Display shows Warning/Failure message. (LOW BATT, STUCK PTT, TX HOT, FAILURE)		Refer to "Warning and Failure Indications", page 113).

Problem	Possible Reason	Proposed Solution
Antenna VSWR exceeds 3:1.	Possibly caused by a defective, or insufficient counterpoise for the antenna.	Check for sufficient size of the counterpoise and make sure there is no mechanical defect on the antenna.
	The impedance of the antenna cable deviates significantly from 50 Ω.	Make sure the used antenna cable has 50 Ω impedance and the cable is not bend or kinked on its way from the radio to the antenna
	Defective BNC connectors on the antenna cable.	Check for proper crimp/solder work on the BNC connectors and rectify as far as necessary.

2.15. Continued Airworthiness

The 620X family maintenance is defined as "on condition" only. No scheduled or regular maintenance of this product is required.

It is recommended to check the frequency accuracy of the airborne transceiver after 7 years.

3. Operating Instructions

In this chapter you can read about:

3.1. Device Description	97
3.1.1. Device Assignment	97
3.1.2. Type Plate	97
3.2. Controls and Indicators	99
3.3. Start-Up	100
3.4. Receive and Transmit Mode	100
3.4.1. Receive Mode	100
3.4.2. Transmit Mode	101
3.5. Frequency Selection Modes	101
3.5.1. Standard Mode	102
3.5.2. Direct Tune Mode	103
3.5.3. Channel Mode	104
3.5.3.1. Select Channels:	104
3.5.4. Frequency Storage Functions	105
3.5.4.1. Store	105
3.5.5. Automatic Storage Function	106
3.5.5.1. Delete data:	106
3.5.6. Scan Mode	107
3.6. SQUELCH	108
3.7. RX Field Strength Indication	108
3.8. Channel Spacing Mode	108
3.9. Auxiliary Audio Input	109
3.10. Intercom Operation	109
3.11. VOX & Speaker Operation	110
3.12. Menus	110
3.12.1. Intercom Menu	110
3.12.2. Pilots Menu	112
3.13. Warning and Failure Indications	113

The chapter "Operating Instructions" in this manual contains general information and instructions to ensure safe operation of the VHF transceivers.

3.1. Device Description

NOTICE

In this section the figures for illustrating display content mainly show transceivers working in 8.33/25 kHz mixed mode. Dedicated pictures for 25 kHz mode are not explicitly shown (they differ only in number of digits for frequency).

The HMI actions described in this section can be performed on primary controller or on optional secondary controller RCU6201. The following graphics of the display content show the 8.33 kHz channel spacing for all possible operation modes.

3.1.1. Device Assignment

- See page 33

3.1.2. Type Plate

- See page 35

NOTICE

Switch OFF the device before starting or shutting down engines.

**SAFETY
INSTRUCTIONS**

A voice communication test shall be performed before starting the engine.

It should be noted that, if the communication test is carried out close to a ground station, the results may be positive even if the antenna cable is broken or short-circuited. In such a case, at a distance of 5 to 10 km and above, communication might not be possible.

- Speak always loud, clear and not too fast for optimal voice communication.
- Keep the microphone always close to the lips otherwise a special suppressing circuit in the VHF COM will not be capable to suppress normal cabin noise.
- Use only microphones or headsets which are suitable for use in an aircraft.
 - In aircraft made of wood, synthetic materials or in gliders or helicopters, incoming radiation can affect the integrated amplifier of the microphone (feedback), noticeable in the ground station by whistling and/or heavy distortion.

If the power supply voltage drops below the "Low Battery Threshold" (default value is 10.5 V), the "LOW BATTERY" message will appear each 3 seconds in the lower part of the display.

**SAFETY
INSTRUCTIONS**

If the power supply voltage drops below 10 V the system enters power saving mode:

- Speaker output of the transceiver is automatically switched "OFF"
- Speaker sign will no longer be presented on LCD display
- The pilot must use headphones to continue listening.

3.2. Controls and Indicators

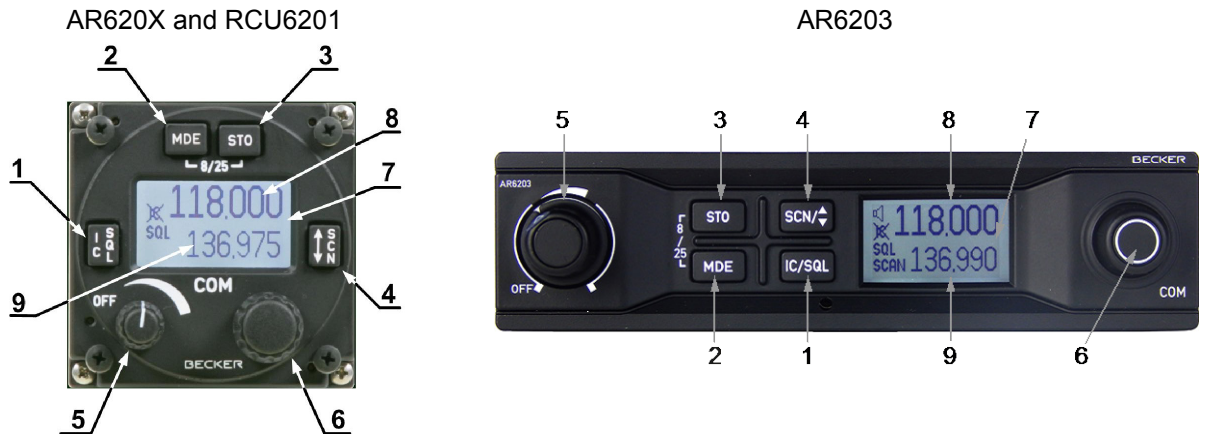

Figure 3-1: Controls and indicators

	Symbol	Description	Main Function
1		IC/SQL (Intercom/Squelch)	"Short press" during normal operation toggles the RX -SQL ON/OFF. "Long press" during normal operation activates Intercom Menu.
2		MDE (Mode)	"Short press" during normal operation changes the frequency selection mode. "Long press" during normal operation activates the pilots menu.
3		STO (Store)	"Short press" during normal operation activates storage procedure.
4		↑/SCN (Exchange/SCAN)	"Short press" during standard mode, or scan mode toggles between preset and active frequency. "Long press" activates scan mode.
5		Power ON/OFF, Volume Knob	Switches the transceiver ON/OFF and adjusts volume level of received signal.
6		Rotary encoder	Turning "ROTARY ENCODER" changes the settings of several parameters (frequency, IC-volume, VOX, ...). Pushing the "ROTARY ENCODER" toggles between the digits and acts as an enter key.
	-8/25-	Change of Channel Spacing	Keeping the MOD and STO button pressed simultaneously longer than 2 seconds changes 8.33 to 25 kHz channel spacing and vice versa.
7		Display	LCD: Liquid Crystal Display
8		Active frequency	Only on the active frequency, transmitting is possible and receiving has priority, even in scan mode. Frequency tuning is not possible in standard mode.
9		Preset frequency	Frequency tuning is possible in standard mode. In scan mode both frequencies, active and preset are in listening watch. If no receive signal is detected on the active frequency, receiving signals on the preset frequency will be audible, but will be muted as soon as a signal on the active frequency is detected.



The device detects a:

"Long press": when pressing and holding down a key for at least 2 seconds.

"Short press": any pressing below 2 seconds.

If any action by the user is invalid, the whole display inverting for a short time.

Symbols shown on the Display

Symbol	Function
IC	Intercom operation is active (triggered by VOX or external IC key)
	Intercom operation via VOX is disabled
TX	The transceiver is in transmit operation
SQL	The squelch function is active, weak RX signals suppressed.
SCAN	Transceiver operates in scan mode
STO	The transceiver performs a storage operation.
LOW BATT	Battery below predefined low threshold
128.225	Inverted figures or letters on display ready to edit
	Speaker on

3.3. Start-Up

NOTICE

Excessive pulses on the DC bus of the aircraft may cause damage on electrical circuits of any installed instrument.

Do not switch ON the device during engine start or shutdown

- Turn "ON" the device by turning the volume knob clockwise.
- During PBIT (Power-On Built In Test) the display indicates the message "WAIT", the software version of "Control Head" (CH) and the software version of "Chassis Module" (CM).
- If the PBIT has detected error(s), "FAILURE" appears on the display (for details see chapter 3.13).

3.4. Receive and Transmit Mode

3.4.1. Receive Mode

If /PTT1 and /PTT2 (Push To Talk) inputs are inactive, the transceiver remains in receive mode.

In receive mode the headphone(s) outputs (if enabled) provide a mixed signal consisting of:

- Received signal from antenna,
- Intercom signal from intercom circuit one and two,
- Signal from auxiliary input.

In receive mode the speaker output (if enabled) provides a mixed signal consisting of:

- Received signal from antenna
- Signal from auxiliary input

The signal from the auxiliary input been muted under certain conditions (For details refer to "Intercom Operation", page 109).

The signal from intercom can be attenuated, or muted, under certain conditions (For details refer to "VOX & Speaker Operation", page 110).

3.4.2. Transmit Mode

If /PTT input is active (PTT=Push To Talk key is pressed) the transceiver switches to transmit mode. Microphone(s) signals can modulate the transmitter.

- PTT 1 input activates transmission from microphone path 1
- PTT 2 input activates transmission from microphone path 2
- If BOTH MIKES are active / enabled in the installation setup, each input (PTT 1 or 2) activates the transmission from both microphone paths simultaneously.

The "TX" symbol in the left upper corner of the display indicates the device is in transmit mode.

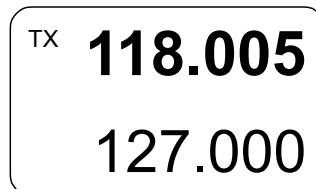

In transmit mode several user actions such as changing frequency selection mode or channel spacing mode, which are normally allowed in receive mode, are blocked. (As an exception in standard mode the "Preset" frequency may still be changeable, even during transmission).

No intercom operation is possible in transmit mode.

The sidetone (demodulated audio of the emitted signal) is available on the headphone output. The transmit mode automatically deactivates the speaker.

Note: **Transmit mode is automatically terminated (return to receive mode) after 120 seconds of continuous transmitting even if PTT is still pressed. In this case "STUCK PTT" is indicated (refer to page 113). For initiation of a new transmission, /PTT line needs first to become inactive.**

3.5. Frequency Selection Modes

Following frequency selection modes are available on AR620X and RCU6201:

- Standard mode
- Direct tune mode
- Channel mode
- Scan mode

The "Standard Mode", "Direct Tune Mode" and "Channel Mode" provide different user interfaces for convenient selection of the operating frequency. These three frequency selection modes are selectable by consecutive short pressing of "MDE" key. They appear in the following order: "Standard Mode", "Direct Tune Mode" "Channel Mode", "Standard Mode", and so on. When toggling between the three modes the active frequency always remains the same and active.

"SCAN Mode" is a sub-mode of standard mode and used for monitoring two frequencies at the same time. A 2 seconds press on "↓/SCN" key activates/deactivates the scan function.

The availability of the modes depends on enabling or disabling in the "Configuration Settings".

3.5.1. Standard Mode

Press the "MDE" key until the standard mode page appears.

The standard mode page displays the active frequency in the top line and preset frequency in the bottom line.



Changing the active frequency is not possible in standard mode (only available in direct tune mode) but changing the preset frequency is possible.

Changing the preset frequency in standard mode:

- Make a "short press" on the "ROTARY ENCODER" for modification of the 100 MHz digits. Rotate the "ROTARY ENCODER" clockwise/counter clockwise to change the frequency in 1 MHz steps.

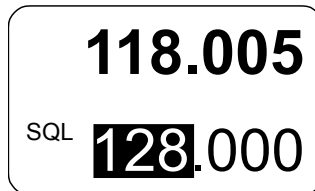

- Make another "short press" on the "ROTARY ENCODER" for modification of the 100 kHz digits. Rotate the "ROTARY ENCODER" clockwise/counter clockwise to change the frequency in 100 kHz steps.

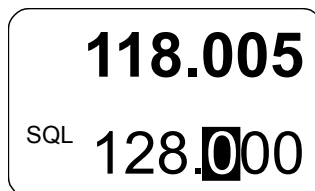

- Make another "short press" on the "ROTARY ENCODER" for modification of the 25/8.33 kHz digits. Rotate the "ROTARY ENCODER" clockwise/counter clockwise to change the frequency in 25/8.33 kHz steps.

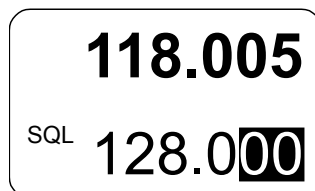

A short press of the "↕/SCN" key, exchanges active frequency to preset frequency and vice versa.

If wanted, please press now the "STO" key to store the active frequency into the next vacant memory place of the user channels database.

Note: While the transceiver operates in transmit mode, the toggle function is disabled.

3.5.2. Direct Tune Mode

Press the "MDE" key until the direct tune mode page appears.

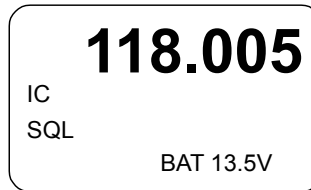

Note: The battery information is only displayed if **BATTERY VOLTAGE** in the installation setup is selected.

In direct tune mode, the active frequency appears in the top line. It can be edited by means of the "ROTARY ENCODER" following the procedure.

Changing the active frequency when in direct tune mode:

- Make a "short press" on the "ROTARY ENCODER" for modification of the 100 MHz digits. Rotate the "ROTARY ENCODER" clockwise/counter clockwise to change the frequency in 1 MHz steps.

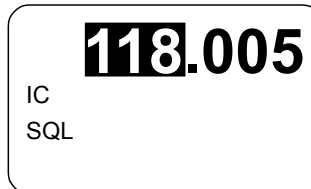

- Make another "short press" on the "ROTARY ENCODER" for modification of the 100 kHz digits. Rotate the "ROTARY ENCODER" clockwise/counter clockwise to change the frequency in 100 kHz steps.

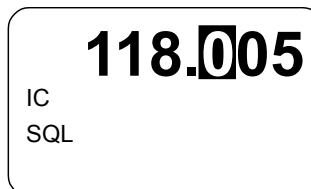

- Make another "short press" on the "ROTARY ENCODER" for modification of the 25/8.33 kHz digits. Rotate the "ROTARY ENCODER" clockwise/counter clockwise to change the frequency in 25/8.33 kHz steps.

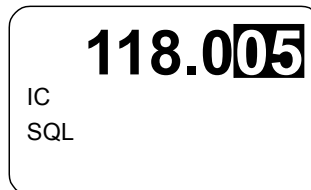

Notes:

The changes become active immediately

Changing the active frequency is possible only when the transceiver is not transmitting.

If wanted, please press now the "STO" key to store the active frequency into the next vacant memory place of the user channels database.

3.5.3. Channel Mode

The channel mode shows data from User Channels Database (indicated by "CH"), or Last Channels Database (indicated by "LAST") and shows if applied a customized label (identifier) for the frequency (max. 10 characters).

The channel database provides storage of:

- CH01 to CH99 and
- LAST 1 to LAST 9.

Note **The functions "LAST" and Store/Restore are only available if this options are activated in "Configuration Settings" - "MEM OPTIONS".**

Note: **If the device is operating in the 25 kHz mode a selection of an earlier stored 8.33 kHz channel is not possible. For selection of 8.33 kHz channels, the device must operate in 8.33 + 25 kHz mixed mode.**

Press the "MDE" key the channel mode page appears.

By means of channel number stored frequencies can be selected. The top line shows the corresponding frequency and the bottom line the customized label (identifier) assigned to the frequency number.

If the active frequency has no assigned channel number the indication is "CH--".

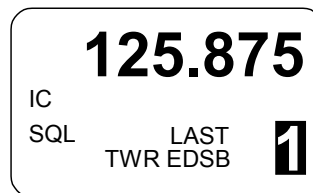
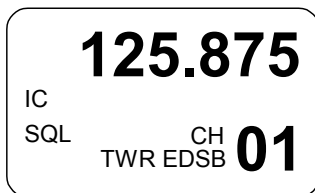

3.5.3.1. Select Channels:

Example: **With CH01 user channel shown on display:**

In order to select the channel number:

- The first turn clockwise in channel mode provides navigation up user channels CH01 to CH99.
 - Make a short press of the "ROTARY ENCODER", or:
 - Make one clockwise turn of the "ROTARY ENCODER".

The channel number is now highlighted and the channel can be changed turning the "ROTARY ENCODER". At each step the receiver tunes immediately to the displayed frequency.

- The first turn counter-clockwise will enter to the channel "LAST 1".
 - The channel number is now highlighted and one of the nine last used channels is selectable by turning the "ROTARY ENCODER" either counter clockwise or clockwise.

The "LAST" mode is left automatically after a 5 second timeout or can be deselected by repeated pressing of the "ROTARY ENCODER".

When leaving the "LAST" channel database and the last shown frequency is not stored in the User channel database, "CH__" appear on the display. Press "STO" to start the storage process.

Leave Channel Mode:

Press the "MDE" key the standard page appears.

3.5.4. Frequency Storage Functions

Start store function by pressing:

- "STO" key in "Standard Mode", "Direct Tune Mode" and "SCAN Mode".
 During this procedure, the display looks similar to the channel mode with one difference that "STO" appears on the left side of the display.

3.5.4.1. Store

The transceiver provides two databases:

- User channels database - provides 99 channels CH01 to CH99 to store frequencies with the possibility to apply a customized label (identifier) with max. 10 alphanumeric characters.
- Last channels database - automatically stores 9 last used frequencies with customized identifier if applied, easy to recall as LAST 1 to LAST 9.

Any frequency can be assigned to any channel within the range from 118.000...136.9916 MHz by simply pressing the "STO" button. All 99 channels are editable. By entering the storage procedure, the device will first propose the next free channel for storing the active frequency. The label "FREE" appears together with the channel number, if the selected channel is vacant. A selected channel with an already stored frequency, has the label "USED".

If the same frequency is stored a second time, then the existing data (frequency, label/identifier data) is offered to store. If the frequency has no label attached, ten underscore digits allows to insert a label. The cursor automatically appears on the first position.

The data can be stored to:

- Next free channel (offered from system).
- A selected free channel.
- A selected used channel (the existing data will be replaced).

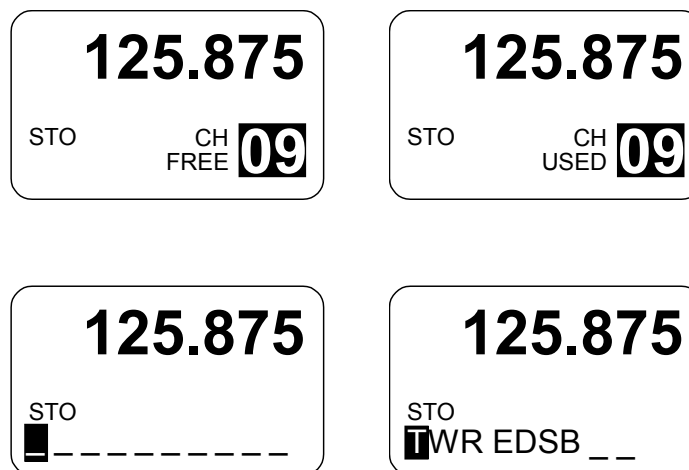

Label (Identifier) Data:

By turning the "ROTARY ENCODER" characters can be selected. Selection works in both directions (example: A→...→Z→0→...→9→—→/→blank→A" by turning clockwise and vice versa by turning counter clockwise).

Each "short press" on the "ROTARY ENCODER", the cursor is passed to the next position. A short press of the "STO" key stores the label a long press of the "STO" key clears the currently edited label. After storing the transceiver returns back to the previous frequency selection mode.

If no action occurs in label editing mode within 7 seconds, the transceiver returns to the previous frequency selection mode without storing the frequency and label information.

Stored frequencies are recallable in Channel Mode (see "Channel Mode" page 104).

3.5.5. Automatic Storage Function

The transceiver stores 9 recently selected frequencies and updates the last channels database during operation in "Standard Mode", "Direct Tune Mode" and "Scan Mode".

When changing to a new active frequency, the previous active frequency is stored "LAST" in memory LAST 1. The frequencies previously located in LAST 1...LAST 8 are shifted to memory channels LAST 2...LAST 9. This algorithm ensures the last 9 used active frequencies are available. Last used frequencies "LAST" can be recalled in channel mode (see "Channel Mode" page 104).

Note The function "LAST" and Store/Restore to channels are only available if this options are activated in "Configuration Settings" - "MEM OPTIONS".

3.5.5.1. *Delete data:*

The stored content in User Channel Database can only be deleted in "Configuration Settings". Please note the whole channel database will be reset.

3.5.6. Scan Mode

In Scan Mode the display shows both the active frequency on the top line and the preset frequency on the bottom line. The SCAN sign in the display indicates that scan function is active.



In all frequency selection modes;

- A long press of "↓/SCN" key activates the scan function and changes to STANDARD MODE if activated from CHANNEL or DIRECT TUNE mode.
- A short press on the "MDE" key or a long press on "SCN" key terminates scan function. After leaving scan function, the device will remain in standard mode.

The arrow sign "▶" in front of the active frequency indicates that this frequency is audible.

If both the active frequency and preset frequency simultaneously detect a signal, the active frequency (top) takes priority. The preset frequency then inverts and blinks.

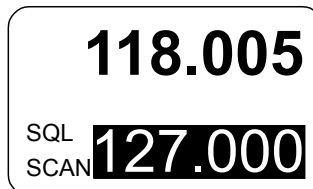

If selected in the installation setup an audio notification "beep" tone becomes audible in addition to the blinking preset frequency to indicate the presence of an RX signal on the preset frequency.

Reception on Preset Frequency in Scan Mode

If the preset frequency detects a signal while no signal is present on the active frequency, the transceiver automatically switches over to the preset frequency.

The arrow sign now appears in front of the preset frequency and the signal is audible.

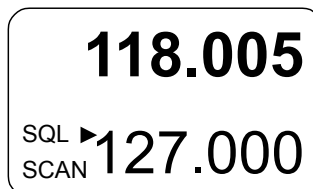

Note: **Transmission always uses the active frequency, even if the monitored frequency is currently audible.**
If TX on the preset frequency is required, push the "↓/SCN" key to swap active and preset frequency.

SQUELCH

3.6. SQUELCH

Independent of the selected operation menu, squelch can be toggled "ON" or "OFF" by a short press on "SQL/IC" key.

- If the squelch function is active ("ON") the receivers noise is muted.
- If the squelch is "OFF" the arrow sign "▶" in front of the active frequency stay visible all the time and receiver noise will be audible as long as signal is receiving.



Squelch "ON"

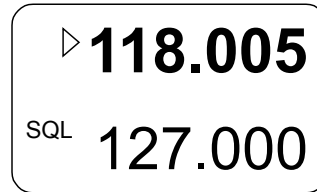

Squelch "OFF"

In the pilots menu, the squelch threshold is adjustable to a convenient trigger level. See "Pilots Menu" page 112.

3.7. RX Field Strength Indication

The field strength indicator, represented by triangle on the left upper corner of the corresponding frequency, will appear next to the active or preset frequency in all frequency selection modes.

The field strength of an incoming signal relates to the measured RSSI level. The three levels displayed are:

Weak Signal Strength	Good Signal Strength	Excellent Signal Strength
RSSI passing squelch levels (empty triangle)	-88 > RSSI > -80 dBm (half-filled triangle)	RSSI > -80 dBm (fully filled triangle)

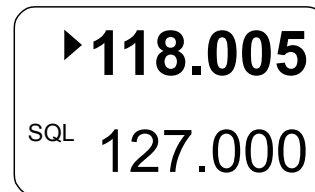
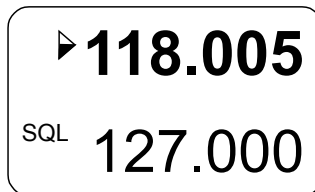
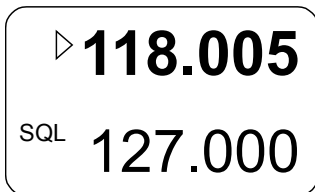

3.8. Channel Spacing Mode

The transceiver provides two operation modes of frequency channel spacing, (8.33 and 25 kHz), selectable by means of pressing "STO" and "MDE" keys simultaneously for at least 2 seconds.

In 25 kHz mode, 5 frequency digits are shown. Only operating frequencies with a channel spacing of 25 kHz are selectable. If 8.33 kHz channels are not in use, this mode provides the advantage of faster tuning since skipping the 8.33 kHz frequency steps.

In 8.33 kHz and 25 kHz mixed mode 6 frequency digits are shown. The transceiver tunes to all possible frequencies within the aviation VHF frequency band. The channel spacing and operating frequency is derived automatically from the selected and displayed frequency.

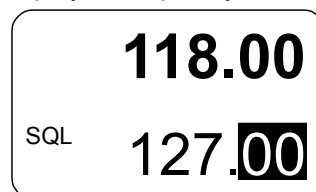
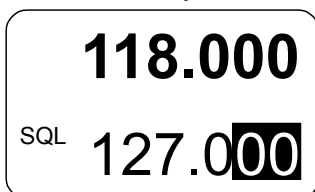

8.33 kHz channel spacing (left) / 25 kHz channel spacing (right)

Toggling between the frequency channel spacing modes is only available for AR-, RCU620X-(0XX) variants. The AR-, RCU620X-(1XX) variants provide operation in 25 kHz Mode only.

3.9. Auxiliary Audio Input

The transceiver has a dedicated auxiliary audio input e.g. for MP3 player connection.

With auxiliary input enabled in installation setup, the auxiliary audio input signal mixing with the received signal from antenna (passing squelch) and the intercom signal (when activated).

When intercom operates in ISOLATION mode, auxiliary audio input signal is audible on headphone 2 output, even if radio communication (transmission/receiving) is active.

AUX AUTO MUTE function depends on the AUX INPUT, selectable via the CONFIGURATION page in the installation setup. This function automatically mutes the audio signal from the auxiliary audio input as long as the AR620X detects (based on squelch evaluation) a RX signal or the user deactivates the squelch manually. If this function is disabled the signal from the auxiliary audio input is permanently audible on the audio output, independently of the received signal or the squelch status.

Automatic aux attenuation functionality controls the auxiliary audio input. The level of the auxiliary input signal attenuates if intercom is activated by VOX or by /IC discrete input. The auxiliary input signal reverts to its previous value after intercom deactivation. The attenuation value can be adjusted within the range from 0...40 dB.

3.10. Intercom Operation

Intercom operation may be triggered automatically via VOX (with adjustable threshold) or externally via intercom switch.

The setting of VOX-threshold and intercom volume is accessible in the pilot intercom menu, in tandem configuration on primary controller only.

For a single block, the primary controller is the one directly connected to VHF transmitter. For a remote VHF transmitter the primary controller is the one connected to primary control interface.

VOX-threshold and intercom volume for the second intercom circuit are controllable from secondary controller RCU6201 (secondary controller is the one connected to secondary control interface).

The transceiver has two internal built in intercom circuits. Therefore, up to four headsets are connectable. Pilot and co-pilot connect to the first intercom circuit. When intercom is active, both microphone signals are mixed and amplified with each other and will be audible on both headphone outputs. This enables internal communication via headsets between both pilots. Passenger headsets are connecting to the second intercom circuit.

ALL mode - Everyone connected to the intercom will hear all communications (pilots hear passengers and passengers hear pilots).

ISOL mode - Provides separate intercoms for the pilots (intercom circuit one) and the passengers (intercom circuit two). This allows pilots to communicate with each other, and air traffic, while the passengers are isolated. The passengers on the intercom circuit two can hear auxiliary audio (for example from mp3 player) and can communicate with each other.

External "ISOL" input provides possibility to switch between ALL mode and ISOL mode. If the /PTT1 input is active and ISOL is active the passenger intercom operation on second intercom circuit is still possible.

While transmit mode intercom operation is degraded. During receive mode the intercom operation activates automatically via VOX (with adjustable threshold), or using the external intercom switch.

If intercom operation is active, the "IC" sign appears in the display.

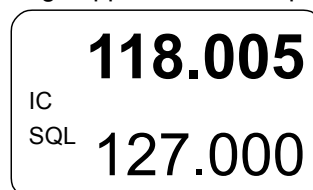

Intercom Operation via VOX

Via VOX, the intercom operation is automatically activated (threshold adjustable in the intercom menu). With additional RCU6201, VOX threshold for the first intercom circuit is adjustable from primary controller (AR620X or RCU6201) and for the second intercom circuit from second controller RCU6201.

Intercom activation via VOX is not possible if:

- It is enabled
- User switched the VOX off

In both cases, VOX is disabled and the display shows the  sign to indicate that activation via VOX is not possible.



Intercom Operation via Intercom Switch

Via intercom switch (pin P1-7) independent of VOX or speaker status (enabled/disabled) the intercom operation can be activated externally. The external intercom switch has priority. During intercom operation the speaker output is disabled.

3.11. VOX & Speaker Operation

Depending on wiring and installation setup, the speaker may either always been enabled, or the speaker can be enabled/disabled by switching configurations using external switch /MIKE_SW.

When speaker enabled and not muted, the display will show the loudspeaker sign. 

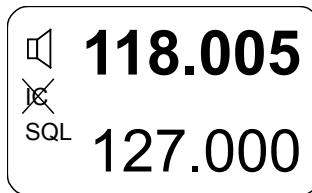

With active enabled speaker in audio configuration, VOX always forced "OFF" and intercom via VOX is not possible (to avoid oscillation of VOX due to acoustical feedback).

In transmission mode the speaker output is muted (switched "OFF") even if speaker is enabled in current audio configuration in one of the following cases:

- Intercom is activated by external intercom switch (I/C input).
- Power is below 10 V.

3.12. Menus

During normal operation in one of the frequency selection modes, the following menus are available:

- The Intercom menu allows adjustment of intercom volume and VOX threshold.
- The Pilots menu allows adjustment of panel brightness and squelch threshold.

3.12.1. Intercom Menu

A long press (2 s) on "IC/SQL" key activates the intercom menu. The page intercom volume appears. In this menu a short press on "IC/SQL" key provides toggling between the pages.

The intercom menu consists of two pages:

- IC VOLUME,
- IC VOX.

A long press on "MDE" key terminates intercom menu, otherwise the menu automatically terminates after 5 seconds timeout.

Intercom Volume Menu

The active frequency is indicated in the top line of the display, the "IC VOLUME" label and a bar graph with numerical value are shown in the bottom line.

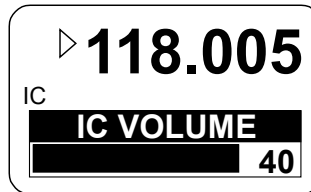

By means of the "ROTARY ENCODER", the intercom volume is changeable from zero to 46. The intercom volume setting affects the intercom audio and sidetone signal, routed to the headphone.

The changes become active immediately.

Intercom VOX Menu

The active frequency is indicated in the top line of the display, the "IC VOX" label and a bar graph with numerical value are shown in the bottom line.



By means of the "ROTARY ENCODER" the intercom VOX threshold can be changed from -30 (most sensitive, even a very low microphone signal already triggers the VOX threshold for Intercom operation) to +10 (VOX is less sensitive and only high microphone signals trigger the VOX threshold for intercom operation).

Note: At a setting for VOX threshold of -15 a convenient behaviour of the VOX should be achieved in most aircraft. This requires that mike sensitivity had been correct adjusted (installation setup). If the mike sensitivity is incorrect adjusted, VOX may not work satisfying.

By changing VOX threshold level to above +10, VOX switches "OFF". In this case, "OFF" replaces the numerical value indication.

The changes become active immediately.

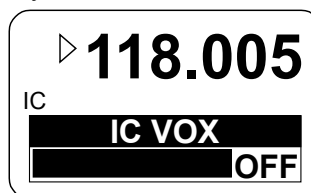

With VOX switched "OFF", activation of intercom operation using the external intercom switch (/IC discrete input) is still possible at any time. The VOX threshold level is not adjustable if VOX forced to be "OFF" (due to enabled speaker in current audio configuration).

In tandem installation the "first" controller adjust VOX threshold for first intercom circuit, and the second controller RCU6201 adjust VOX threshold for second intercom circuit.

3.12.2. Pilots Menu

Press the "MDE" key for 2 seconds to start the pilots menu. Toggling between the pages by a short press of the "MDE" key, or by a short press of the "ROTARY ENCODER".

The pilots menu consists of two pages:

- BRIGHTNESS
- SQUELCH TRH

To exit the pilots menu either

- Wait 5 seconds without any switch selections.
- Press the "MDE" key again for 2 second,
- Press the "ROTARY ENCODER" when the SQUELCH setting page is visible,

BRIGHTNESS

The active frequency appears in the top line of the display "BRIGHTNESS" label appears in combination with a bar graph and the selected value.



The panel brightness for display illumination and push buttons can be changed from 0 (illumination off) to 100 (maximum brightness) by turning the "ROTARY ENCODER".

Note: This page is not available if in installation setup the dimming input is set to 14 V or 28 V. For this setting, the aircraft dimming circuit controls the brightness parameters.

SQUELCH

A short press on the "ROTARY ENCODER" provides "SQUELCH" trigger level adjustment. The active frequency appears in the top line of the display. On the bottom line "SQUELCH" with bar graph and value is indicated.

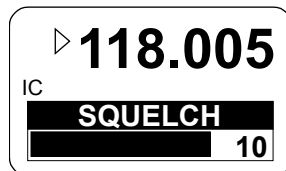

By means of the "ROTARY ENCODER", the squelch threshold is adjustable:

- At a setting to 6 (very weak signals are audible with high noise content; squelch opens at about -105 dBm).
- At a setting to 26 (only quite strong signals are audible with low noise content; squelch opens at about -87 dBm). With this adjustment the receiver sensitivity is significant reduced.

3.13. Warning and Failure Indications

Display Contents	Description
<div style="border: 1px solid black; border-radius: 10px; padding: 10px; text-align: center;"> <p>IC</p> <p>118.005</p> <p>LOW BATTERY</p> </div> <p>Appear in 3-second cycle</p>	<p>"LOW BATT" is indicated if the supply voltage of the transceiver is below the threshold defined in the installation setup.</p> <p>The transceiver is still operable but may have a reduced performance depending on supply voltage.</p> <p>Possible reasons for indication:</p> <ul style="list-style-type: none"> Accumulator capacity problems (gliders), Power interrupts, General power supply problems, Setting for low battery threshold too high
<div style="border: 1px solid black; border-radius: 10px; padding: 10px; text-align: center;"> <p>IC</p> <p>118.005</p> <p>STUCK PTT</p> </div> <p>Appear in 3-second cycle</p>	<p>"STUCK PTT" is indicated after 120 seconds of continued transmission. The transceiver goes back to receive mode even if the PTT line is still active (GND).</p> <p>For initiating a new transmission, the PTT line needs first to become inactive (open).</p> <p>Possible reasons for indication:</p> <ul style="list-style-type: none"> Transmission lasts more than 120 seconds. PTT-key is stuck. PTT line permanently grounded (short circuit in installation).
<div style="border: 1px solid black; border-radius: 10px; padding: 10px; text-align: center;"> <p>IC</p> <p>118.005</p> <p>TX HOT</p> </div> <p>Appear in 3-second cycle</p>	<p>"TX HOT" is indicated if the internal device temperature exceeds +90 °C.</p> <p>Transceiver is still operable. Performance of transmitter is reduced.</p> <p>Possible reasons for indication:</p> <ul style="list-style-type: none"> Very hot environmental temperature, long transmissions times and insufficient airflow conditions.
<div style="border: 1px solid black; border-radius: 10px; padding: 10px; text-align: center;"> <p>IC</p> <p>118.005</p> <p>FAILURE</p> </div> <p>Appear in 3-second cycle</p>	<p>The transceiver has detected an internal failure during normal operation.</p> <p>Depending on failure reason, the device may still be operable with degraded performance, or not operable at all.</p> <p>Possible reasons for indication:</p> <ul style="list-style-type: none"> Specified environmental conditions HW or SW failure inside the transceiver. <p>Contact maintenance shop for assistance.</p>
<div style="border: 1px solid black; border-radius: 10px; padding: 10px; text-align: center;"> <p>FAILURE</p> <p>PRESS ANY KEY</p> </div>	<p>The transceiver has detected an internal failure during start up.</p> <p>Depending on failure reason, the device may be still operable with degraded performance or not operable at all.</p> <p>Possible reasons for indication:</p> <ul style="list-style-type: none"> Outside specified environmental conditions HW or SW failure inside the transceiver. <p>Contact maintenance shop for assistance.</p>
<div style="border: 1px solid black; border-radius: 10px; padding: 10px; text-align: center;"> <p>FAILURE</p> </div>	<p>The transceiver has no communication with the controller.</p> <p>Depending on failure reason, the device may be still operable with degraded performance or not operable at all.</p> <p>Possible reasons for indication:</p> <ul style="list-style-type: none"> Problem with inter-wiring <p>Contact maintenance shop for assistance.</p>

In case of additional questions contact your local BECKER dealer or forward your request direct to BECKER "Product Support Department".

In the event of damage or a defect, the entire device must be returned for repair. The repair must be made by trained BECKER personnel.

Becker Avionics GmbH • Baden-Airpark B108 • 77836 Rheinmünster • Germany

☎ +49 (0) 7229 / 305-0 • Fax +49 (0) 7229 / 305-217

Customer Service:

Sales

Email: sales@becker-avionics.com

Support in German or English

Email: support@becker-avionics.com

Support in French

E-Mail: FR-sales@becker-avionics.com

User Conversions and Changes are Not Permitted

Any change made by the user excludes any liability on our part (excluding updates for the navigation data base and excluding the work described in this manual).

4. Index

Abbreviations	7	List of Abbreviations	7
Accessories	30	LOW BATT Indication	20
Activation of Intercom Operation via Intercom Switch	110	Memory Channels	19
Activation of Intercom Operation via VOX	109	Menus	110
Additional Conditions of Utilization	9	Mike Inputs	19
AF Auxiliary Input	19	Non Warranty Clause	9
ALL Mode	109	Operation Instructions	97
Antenna Installation	53	Packaging, Transport, Storage	33
AR6201 Single Block Transceiver	16	PBIT	20
AR6203 Single Block Transceiver	18	Pilots Menu	112
Audio Outputs	19	Post Installation Tests	92
Automatic Storage Function	106	Purpose of Equipment	13
Auxiliary Audio Input	109	RCU6201 Remote Control Unit	17
BRIGHTNESS	112	Receive and Transmit Mode	100
Built-in Tests PBIT and CBIT	20	Receive Mode	100
CBIT	20	Reception on Preset Frequency in Scan Mode ...	107
Channel Mode	104	Retrofitting	89
Conditions of Utilization	9	RT6201 Remote Transceiver	17
Controls and Indicators	99	RX Field Strength Indication	108
Device Assignment	34, 97	Sales	114
Direct Tune Mode	103	Scan Mode	19, 107
Electrical Interface	44	Scope of Delivery	34
Emergency Operation	20	Service Mode	20
Environmental Qualification AR620X, RCU6201 ...	25	Side Tone	19
Environmental Qualification RT6201	26	Squelch	108
Factory Default Settings	68	SQUELCH	112
Features Overview	18	Squelch Operation	19
First Issue and Changes	3	Standard Mode	102
Frequency Selection Modes	101	Support	114
General Description	11	Support in French	114
General Safety Definitions	8	Tandem Operation	20
Illumination	20	Technical Data	21
Installation	33	Transmit Mode	101
Installation and Configuration	52	Trouble Shooting	95
Installation Setup	20, 53	Typical Installations with Recommended Settings and Wiring Diagrams	70
Intercom Menu	110	Units	8
Intercom Operation	19, 109	Variants Overview	14
Intercom Volume Menu	111	VOX & Speaker Operation	110
Intercom VOX Menu	111	Warning and Failure Indications	113
ISOL Mode	109	Warranty Conditions	9

We reserve the right to make technical changes.
The data correspond to the current status at the time of printing.

***** End of the Document *****